

**Multi-CD control High power CD/MP3 player with FM/AM tuner**

**Syntoniseur FM/AM et lecteur de CD/MP3, "Puissance élevée", avec contrôleur pour lecteur de CD à chargeur**

**PREMIER**

**SUPER TUNER III**

**Operation Manual**

**DEH-P740MP**

**Mode d'emploi**

English

Français

## Thank you for buying this Pioneer product.

Please read through these operating instructions so you will know how to operate your model properly. *After you have finished reading the instructions, put them away in a safe place for future reference.*

### 01 Before You Start

- About this unit **6**
- About this manual **6**
- After-sales service for Pioneer products **6**
- Precautions **7**
- Features **7**
  - CD playback **7**
  - MP3 file playback **7**
- Use and care of the remote control **7**
  - Installing the battery **7**
  - Using the remote control **7**
- About the XM READY mark **8**
- Protecting your unit from theft **8**
  - Removing the front panel **8**
  - Attaching the front panel **9**
- About the demo mode **9**
  - Reverse mode **9**
  - Feature demo **9**
- What's what **10**
  - Head Unit **10**
  - Remote control **11**

### 02 Power ON/OFF

- Turning the unit on **12**
- Selecting a source **12**
- Turning the unit off **12**

### 03 Tuner

- Listening to the radio **13**
- Introduction of advanced tuner operation **14**
- Storing and recalling broadcast frequencies **14**
- Tuning in strong signals **15**
- Storing the strongest broadcast frequencies **15**

### 04 Built-in CD Player

- Playing a CD **16**
- Introduction of advanced built-in CD player operation **17**
- Repeating play **17**
- Playing tracks in a random order **17**
- Scanning tracks of a CD **18**
- Pausing CD playback **18**
- Using disc title functions **18**
  - Entering disc titles **18**
  - Displaying disc titles **19**
- Using CD TEXT functions **19**
  - Displaying titles on CD TEXT discs **19**
  - Scrolling titles in the display **19**

### 05 MP3 Player

- Playing a MP3 **20**
- Introduction of advanced built-CD player (MP3) operation **21**
- Repeating play **21**
- Playing tracks in a random order **22**
- Scanning folders and tracks **22**
- Pausing MP3 playback **23**
- Displaying titles on MP3 disc **23**
- Scrolling titles in the display **23**



**06 Multi-CD Player**

- Playing a CD **24**
- 50-disc multi-CD player **24**
- Introduction of advanced multi-CD player operation **25**
- Repeating play **25**
- Playing tracks in a random order **26**
- Scanning CDs and tracks **26**
- Pausing CD playback **26**
- Using ITS playlists **27**
  - Creating a playlist with ITS programming **27**
  - Playback from your ITS playlist **27**
  - Erasing a track from your ITS playlist **28**
  - Erasing a CD from your ITS playlist **28**
- Using disc title functions **28**
  - Entering disc titles **28**
  - Displaying disc titles **29**
  - Selecting discs from the disc title list **29**
- Using CD TEXT functions **30**
  - Displaying titles on CD TEXT discs **30**
  - Scrolling titles in the display **30**
- Using compression and bass emphasis **30**

**07 Audio Adjustments**

- Introduction of audio adjustments **31**
- Setting the sound focus equalizer **31**
- Using balance adjustment **32**
- Using the equalizer **32**
  - Recalling equalizer curves **32**
  - Adjusting equalizer curves **33**
  - Fine adjusting equalizer curve **33**
- Adjusting bass **34**
- Adjusting treble **34**
- Adjusting loudness **34**
- Using subwoofer output **34**
  - Adjusting subwoofer settings **35**
- Using non fading output **35**
  - Adjusting non fading output level **35**
- Using the high pass filter **36**
- Adjusting source levels **36**

**08 Initial Settings**

- Adjusting initial settings **37**
- Setting the time **37**
- Switching the warning tone **37**
- Switching the auxiliary setting **38**
- Switching the dimmer setting **38**
- Selecting the brightness **38**
- Setting the rear output and subwoofer controller **38**
- Switching the Telephone Muting/Attenuation **39**

**09 Other Functions**

Setting the time display on or off **40**

Using different entertainment displays **40**

Using the AUX source **40**

- Selecting AUX as the source **40**
- Setting the AUX title **40**

Using the telephone muting/attenuation function **41**

Introduction of XM operation **42**

- Operation **42**
- Switching the display **42**
- Switching the channel select mode **42**
- Display the ID code **43**

**10 Additional Information**

CD player and care **43**

CD-R/CD-RW discs **44**

Understanding built-in CD player error messages **45**

MP3 files **46**

About folders and MP3 files **47**

Terms **48**

Specifications **49**



## Dear Customer:

Selecting fine audio equipment such as the unit you've just purchased is only the start of your musical enjoyment. Now it's time to consider how you can maximize the fun and excitement your equipment offers. This manufacturer and the Electronic Industries Association's Consumer Electronics Group want you to get the most out of your equipment by playing it at a safe level. One that lets the sound come through loud and clear without annoying blaring or distortion—and, most importantly, without affecting your sensitive hearing.

Sound can be deceiving. Over time your hearing "comfort level" adapts to higher volumes of sound. So what sounds "normal" can actually be loud and harmful to your hearing. Guard against this by setting your equipment at a safe level BEFORE your hearing adapts.

### To establish a safe level:

- Start your volume control at a low setting.
- Slowly increase the sound until you can hear it comfortably and clearly, and without distortion.

### Once you have established a comfortable sound level:

- Set the dial and leave it there.

Taking a minute to do this now will help to prevent hearing damage or loss in the future. After all, we want you listening for a lifetime.

## We Want You Listening For A Lifetime

Used wisely, your new sound equipment will provide a lifetime of fun and enjoyment. Since hearing damage from loud noise is often undetectable until it is too late, this manufacturer and the Electronic Industries Association's Consumer Electronics Group recommend you avoid prolonged exposure to excessive noise. This list of sound levels is included for your protection.

### Decibel

Level	Example
30	Quiet library, soft whispers
40	Living room, refrigerator, bedroom away from traffic
50	Light traffic, normal conversation, quiet office
60	Air conditioner at 20 feet, sewing machine
70	Vacuum cleaner, hair dryer, noisy restaurant
80	Average city traffic, garbage disposals, alarm clock at two feet.

### THE FOLLOWING NOISES CAN BE DANGEROUS UNDER CONSTANT EXPOSURE

90	Subway, motorcycle, truck traffic, lawn mower
100	Garbage truck, chain saw, pneumatic drill
120	Rock band concert in front of speakers, thunderclap
140	Gunshot blast, jet plane
180	Rocket launching pad

Information courtesy of the Deafness Research Foundation.



## About this unit

The tuner frequencies on this unit are allocated for use in North America. Use in other areas may result in improper reception.



### Important

The serial number is located on the bottom of this unit. For your own security and convenience, be sure to record this number on the enclosed warranty card. ■

## About this manual

This unit features a number of sophisticated functions ensuring superior reception and operation. All the functions have been designed for the easiest possible use, but many are not self-explanatory. This operation manual will help you benefit fully from this product's potential and to maximize your listening enjoyment.

We recommend that you familiarize yourself with the functions and their operation by reading through the manual before you begin using this unit. It is especially important that you read and observe precautions on this page and in other sections.

This manual explains head unit operation. You can perform the same operations with the remote control. ■

## After-sales service for Pioneer products

Please contact the dealer or distributor from where you purchased this unit for after-sales service (including warranty conditions) or any other information. In case the necessary information is not available, please contact the companies listed below:

Please do not ship your unit to the companies at the addresses listed below for repair without advance contact.

### U.S.A.

Pioneer Electronics (USA), Inc.  
CUSTOMER SUPPORT DIVISION  
P.O. Box 1760  
Long Beach, CA 90801-1760  
800-421-1404

### CANADA

Pioneer Electronics of Canada, Inc.  
CUSTOMER SATISFACTION DEPARTMENT  
300 Allstate Parkway  
Markham, Ontario L3R OP2  
(905) 479-4411  
1-877-283-5901

For warranty information please see the Limited Warranty sheet included with this unit. ■



## Before You Start

### Precautions

**CAUTION: USE OF CONTROL OR ADJUSTMENT OR PERFORMANCE OF PROCEDURES OTHER THAN THOSE SPECIFIED HEREIN MAY RESULT IN HAZARDOUS RADIATION EXPOSURE.**

**CAUTION: THE USE OF OPTICAL INSTRUMENTS WITH THIS PRODUCT WILL INCREASE EYE HAZARD.**

- Keep this manual handy as a reference for operating procedures and precautions.
- Always keep the volume low enough so you can hear sounds outside of the car.
- Protect this product from moisture.
- If the battery is disconnected or discharged, the preset memory will be erased and must be reprogrammed. 

### Features

#### CD playback

Music CD/CD-R/CD-RW playback is possible.

#### MP3 file playback

It is possible to play back MP3 files recorded on CD-ROM/CD-RW (ISO9660 Level 1/Level 2 standard recordings). (refer to page 20.)

### Use and care of the remote control

#### Installing the battery

Slide the tray out on the back of the remote control and insert the battery with the plus (+) and minus (-) poles pointing in the proper direction.

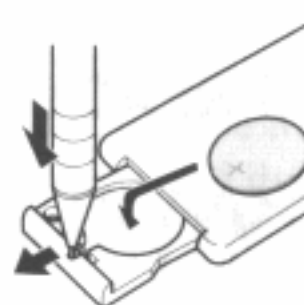

#### WARNING

Keep the battery out of the reach of children. Should the battery be swallowed, immediately consult a doctor.

#### CAUTION

- Use only one **CR2025 (3V)** lithium battery.
- Remove the battery if the remote control is not to be used for a month or longer.
- Do not recharge, disassemble, heat or dispose of battery in fire.
- Do not handle the battery with metallic tools.
- Do not store the battery with metallic materials.
- In the event of battery leakage, wipe the remote control completely clean and install a new battery.
- When disposing of used batteries, please comply with governmental regulations or environmental public institution's rules that apply in your country/area.

#### Using the remote control

Point the remote control in the direction of the front panel to operate.

### Important

- Do not store the remote control in high temperatures or direct sunlight.
- The remote control may not function properly in direct sunlight.
- Do not let the remote control fall onto the floor, where it may become jammed under the brake or accelerator pedals. 

### About the XM READY mark



The XM READY mark printed on the front panel indicates that the Pioneer XM tuner (sold separately) can be controlled by this unit. Please inquire to your dealer or nearest authorized Pioneer service station regarding the XM tuner that can be connected to this unit. For XM tuner operation, please refer to the XM tuner owner's manual.

### Notes



- XM Satellite Radio is developing a new band of radio in the U.S.A.  
The system will use direct satellite-to-receiver broadcasting technology to provide listeners in their cars and at home with crystal-clear sound seamlessly from coast to coast. XM will create and package up to 100 channels of digital-quality music, news, sports, talk and children's programming. 

### Protecting your unit from theft

The front panel can be detached from the head unit and stored in the protective case provided to discourage theft.

- If the front panel is not detached from the head unit within five seconds of turning off the ignition, a warning tone will sound.
- You can turn off the warning tone. See *Switching the warning tone* on page 37.

### Important

- Never use force or grip the display and the buttons tightly when removing or attaching.
- Avoid subjecting the front panel to excessive shocks.
- Keep the front panel out of direct sunlight and high temperatures.

### Removing the front panel

- 1 Press OPEN to open the front panel.**
- 2 Grip the left side of the front panel and pull it gently outward.**

Take care not to grip it tightly or drop it.

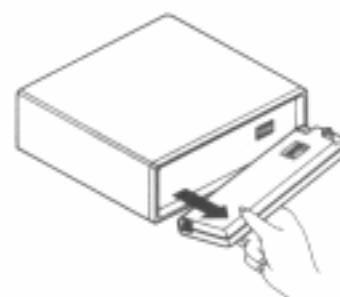

- 3 Put the front panel into the protective case provided for safe keeping.**



## Before You Start

### Attaching the front panel

Replace the front panel by holding it upright to this unit and clipping it securely into the mounting hooks.

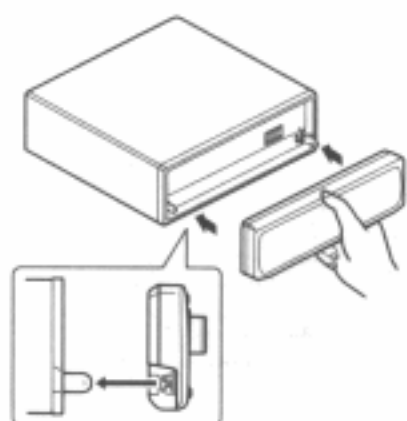

### About the demo mode

This product features two demonstration modes. one is the reverse mode, the other is the feature demo mode.

#### Reverse mode

If you do not perform an operation within about 30 seconds, screen indications start to reverse, and then continue reversing every 10 seconds. Pressing 5 numbered button when power to this product is switched off while the ignition switch is set to ACC or ON cancels the reverse mode. Pressing 5 numbered button again to start the reverse mode.

#### Feature demo

The feature demo automatically starts when power to this product is switched off while the ignition switch is set to ACC or ON. Pressing 6 numbered button during feature demo operation cancels the feature demo mode. Pressing 6 numbered button again to start the feature mode. remember that if the feature demo continues operating when the car engine is switched off, it may drain battery power.



#### Notes

- You cannot cancel a demo mode when the front panel is open.
- The red lead (ACC) of this product should be connected to a terminal coupled with ignition switch on/off operations. If this is not done, the vehicle battery may be drained. ■

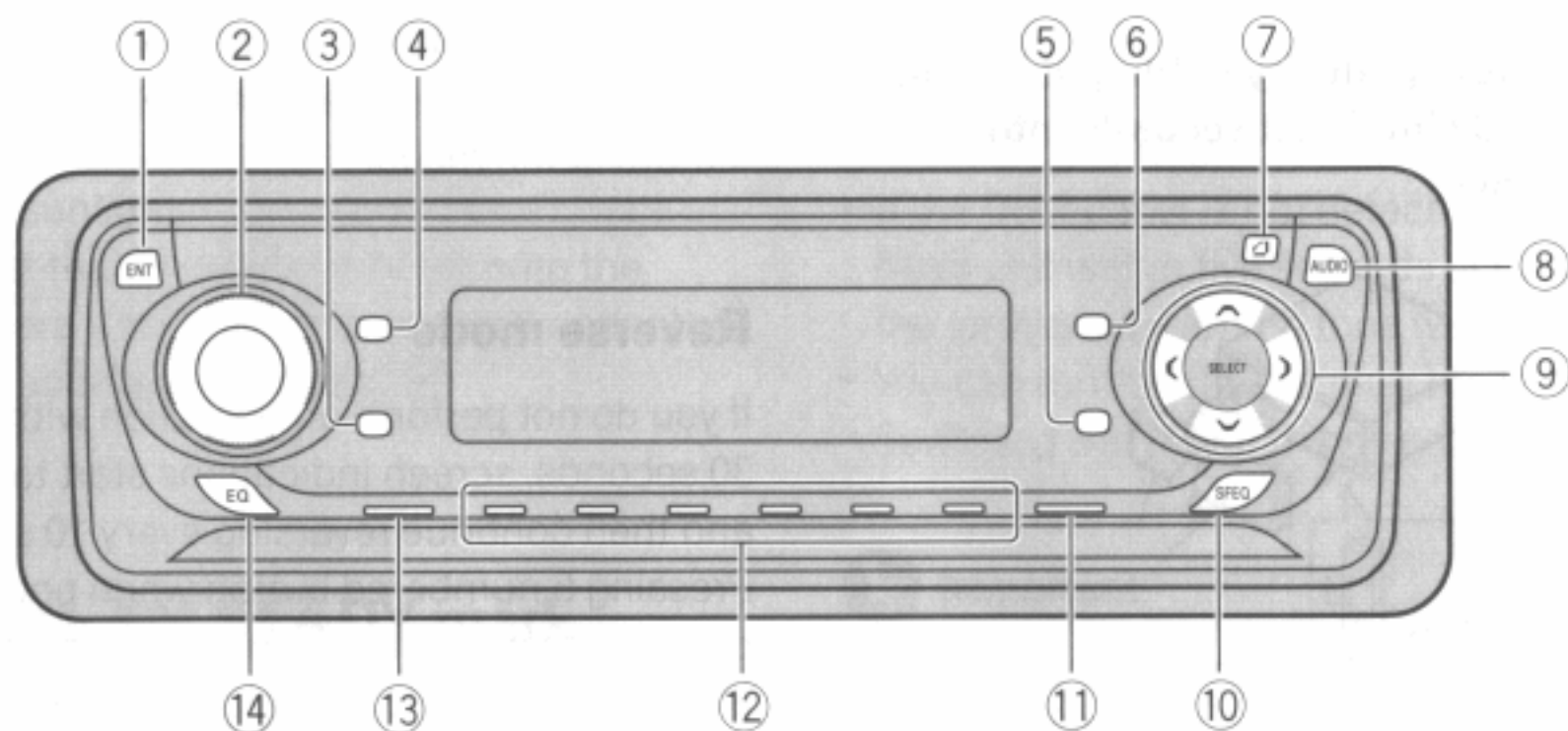

## What's what

### Head Unit

- ① **ENTERTAINMENT button**  
Press to change to the entertainment display.
- ② **VOLUME**  
When you press the **VOLUME**, it extends outward so that it becomes easier to turn. To retract the **VOLUME**, press it again. Rotate to increase or decrease the volume.
- ③ **CLOCK button**  
Press to change to the clock display.
- ④ **DISPLAY button**  
Press to select different displays.
- ⑤ **PAUSE button**  
Press to pause play.
- ⑥ **FUNCTION button**  
Press to select functions.
- ⑦ **OPEN button**  
Press to open the front panel.
- ⑧ **AUDIO button**  
Press to select various sound quality controls.
- ⑨ **▲/▼/◀/▶ buttons**  
Press to do manual seek tuning, fast forward, reverse and track search controls. Also used for controlling functions.
- ⑩ **SFEQ button**  
Press to select a natural sound with presence.
- ⑪ **BAND/ESC button**  
Press to select among three FM and one AM bands and cancel the control mode of functions.
- ⑫ **1-6 (PRESET TUNING) buttons**  
Press for preset tuning and disc number search when using a multi-CD player.
- ⑬ **SOURCE button**  
This unit is switched on by selecting a source. Press to cycle through all of the available sources.

## Before You Start

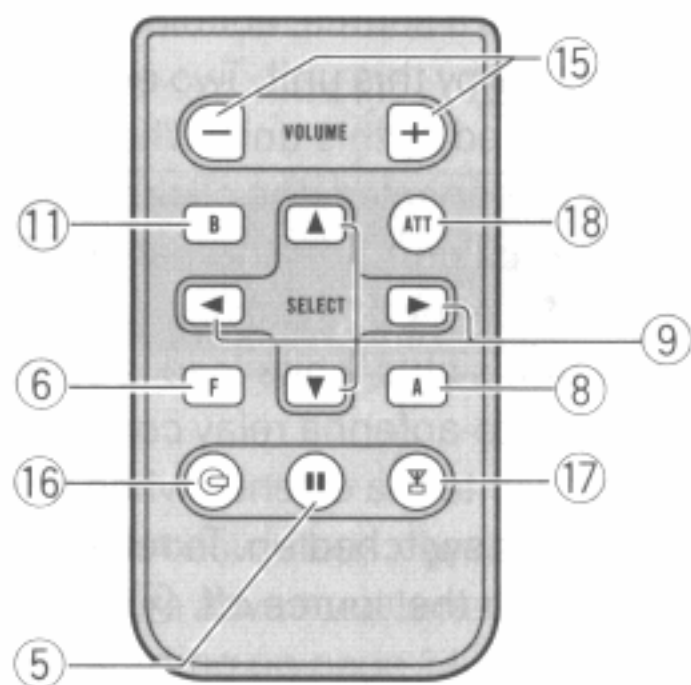

### 14 EQ button

Press to select various equalizer curves.

## Remote control

The supplied remote control enables convenient remote operation of the head unit. Operation is the same as when using button on the head unit.

### 15 VOLUME button

Press to increase or decrease the volume.

### 16 CD button

Press to select the built-in or multi-CD player as source.

### 17 TUNER button

Press to select the tuner as source.

### 18 ATT button

Press to quickly lower the volume level, by about 90%. Press once more to return to the original volume level.



## Turning the unit on

### Press SOURCE to turn the unit on.

When you select a source the unit is turned on.



## Selecting a source

You can select a source you want to listen to. To switch to the built-in CD player, load a disc in this unit (refer to page 16).

### • When using the head unit, press SOURCE to select a source.

Press **SOURCE** repeatedly to switch between the following sources:

**Built-in CD player—TV—Tuner—XM tuner—  
Multi-CD player—External unit 1—External unit 2  
—AUX**

### • When using the remote control, press TUNER, or CD to select a source.

Press each button repeatedly to switch between the following sources:

**TUNER: TV—Tuner—XM tuner—Sources off  
CD: Built-in CD player—Multi-CD player—  
Sources off**



### Notes

- In the following cases, the sound source will not change:
  - When a product corresponding to each source is not connected to this unit.
  - When no disc is set in this unit.
  - When no magazine is set in the multi-CD player.
  - When the AUX (auxiliary input) is set to off (refer to page 38).

- External unit refers to a Pioneer product (such as one available in the future) that, although incompatible as a source, enables control of basic functions by this unit. Two external units can be controlled by this unit. When two external units are connected, the allocation of them to external unit 1 or external unit 2 is automatically set by this unit.
- When this unit's blue/white lead is connected to the car's auto-antenna relay control terminal, the car's antenna extends when this unit's source is switched on. To retract the antenna, switch the source off. 

## Turning the unit off

Press **SOURCE** and hold for at least one second to turn the unit off. 

# Tuner

## Listening to the radio

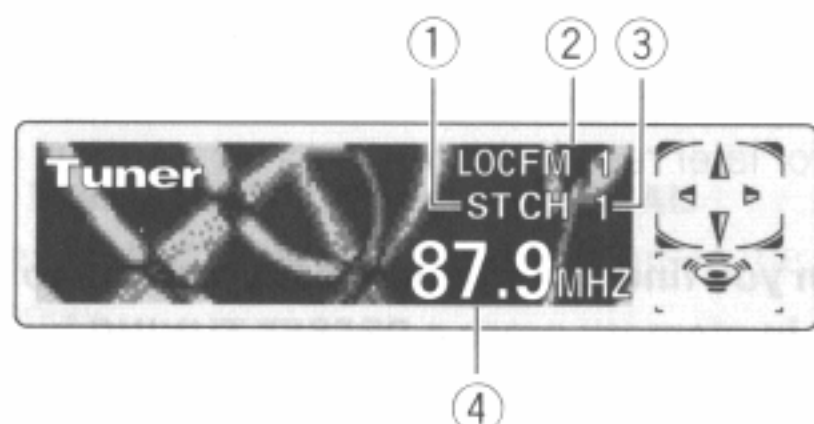

These are the basic steps necessary to operate the radio. More advanced tuner operation is explained starting on page 14.

### ① **STEREO (ST) indicator**

Shows that the frequency selected is being broadcast in stereo.

### ② **BAND indicator**

Shows which band the radio is tuned to, AM or FM.

### ③ **PRESET NUMBER indicator**

Shows what preset has been selected.

### ④ **FREQUENCY indicator**

Shows to which frequency the tuner is tuned.

### 1 Press **SOURCE** to select the tuner.

Press **SOURCE** until you see **Tuner** displayed.

### 2 Use **VOLUME** to adjust the sound level.

Rotate to increase or decrease the volume.

### 3 Press **BAND/ESC** to select a band.

Press **BAND/ESC** until the desired band is displayed, **FM1**, **FM2**, **FM3** for FM or **AM**.

### 4 To perform manual tuning, press ◀ or ▶ with quick presses.

The frequencies move up or down step by step.

### 5 To perform seek tuning, press and hold ◀ or ▶ for about one second and release.

The tuner will scan the frequencies until a broadcast strong enough for good reception is found.

- You can cancel seek tuning by pressing either ◀ or ▶ with a quick press.
- If you press and hold ◀ or ▶ you can skip broadcasting stations. Seek tuning starts as soon as you release the buttons.



#### Note

- When the frequency selected is being broadcast in stereo the **STEREO (ST)** indicator will light.

## Introduction of advanced tuner operation

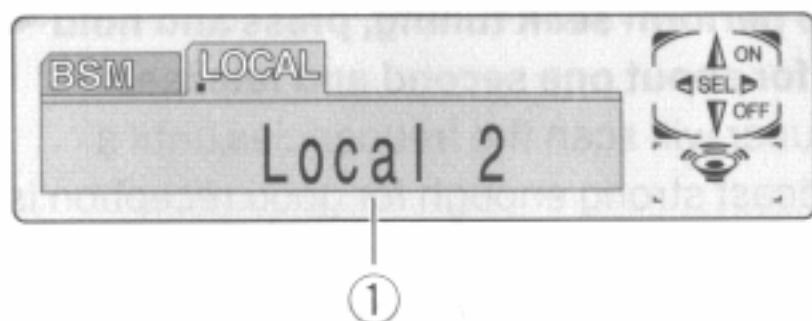

### ① FUNCTION display

Shows the function status.

### Press FUNCTION to display the function names.

Press **FUNCTION** repeatedly to switch between the following functions:

**BSM** (best stations memory)—**LOCAL** (local seek tuning)

- To return to the frequency display, press **BAND/ESC**.

### Note

- If you do not operate the function within about 30 seconds, the display is automatically returned to the frequency display. 

## Storing and recalling broadcast frequencies

If you press any of the **PRESET TUNING** buttons you can easily store up to six broadcast frequencies for later recall with the touch of a button.

### When you find a frequency that you want to store in memory press a **PRESET TUNING** button and hold until the preset number stops flashing.

The number you have pressed will flash in the **PRESET NUMBER** indicator and then remain lit. The selected radio station frequency has been stored in memory.

The next time you press the same **PRESET TUNING** button the radio station frequency is recalled from memory.

### Notes

- Up to 18 FM stations, 6 for each of the three FM bands, and 6 AM stations can be stored in memory.
- You can also use **▲** and **▼** to recall radio station frequencies assigned to **PRESET TUNING** buttons. 



## Tuner

### Tuning in strong signals

Local seek tuning lets you tune in only those radio stations with sufficiently strong signals for good reception.

#### 1 Press **FUNCTION** to select **LOCAL**.

Press **FUNCTION** until **Local** appears in the display.

#### 2 Press **▲** to turn local seek tuning on.

Local seek sensitivity (e.g., **Local 2**) appears in the display.

#### 3 Press **◀** or **▶** to set the sensitivity.

There are four levels of sensitivity for FM and two levels for AM:

**FM: Local 1—Local 2—Local 3—Local 4**

**AM: Local 1—Local 2**

The **Local 4** setting allows reception of only the strongest stations, while lower settings let you receive progressively weaker stations.

#### 4 When you want to return to normal seek tuning, press **▼** to turn local seek tuning off.

**Local :OFF** appears in the display.

### Storing the strongest broadcast frequencies

BSM (best stations memory) lets you automatically store the six strongest broadcast frequencies under **PRESET TUNING** buttons **1–6** and once stored there you can tune in to those frequencies with the touch of a button.

#### 1 Press **FUNCTION** to select **BSM**.

Press **FUNCTION** until **BSM** appears in the display.

#### 2 Press **▲** to turn **BSM** on.

**BSM** begins to flash. While **BSM** is flashing the six strongest broadcast frequencies will be stored under **PRESET TUNING** buttons in order of their signal strength. When finished, **BSM** stops flashing.

- To cancel the storage process, press **▼**.



#### Note

- Storing broadcast frequencies with BSM may replace broadcast frequencies you have saved using **PRESET TUNING**.

## Playing a CD

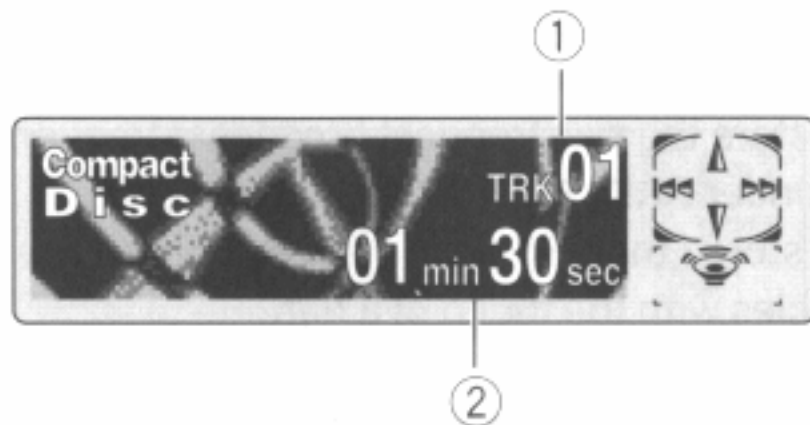

These are the basic steps necessary to play a CD with your built-in CD player. More advanced CD operation is explained starting on page 17.

### ① TRACK NUMBER indicator

Shows the track currently playing.

### ② PLAY TIME indicator

Shows the elapsed playing time of the current track.

### 1 Press OPEN to open the front panel.

CD loading slot appears.

- After inserting a CD, press **SOURCE** to select the built-in CD player.

### 2 Insert a CD into the CD loading slot.

Playback will automatically start.

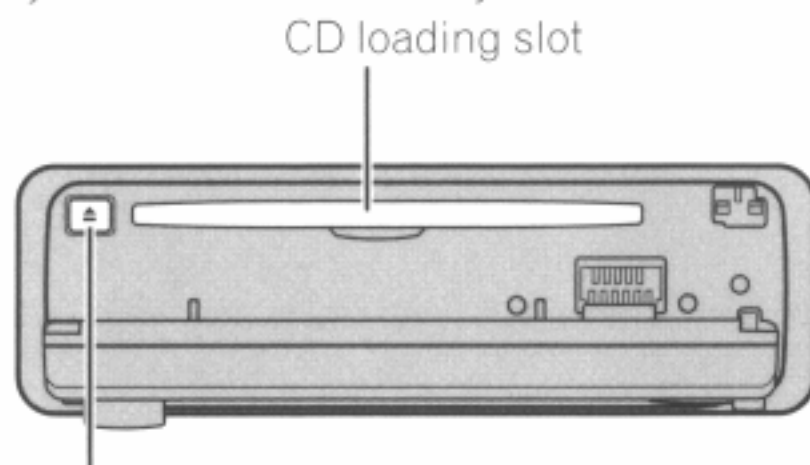

### EJECT button

- You can eject a CD by pressing **EJECT**.
- To avoid a malfunction, make sure that no metal object comes into contact with the front panel is open.

### 3 After a CD has been inserted, close the front panel.

### 4 Use VOLUME to adjust the sound level.



Rotate to increase or decrease the volume.

### 5 To perform fast forward or reverse, press and hold ◀ or ▶.

### 6 To skip back or forward to another track, press ◀ or ▶.

Pressing ▶ skips to the start of the next track. Pressing ◀ once skips to the start of the current track. Pressing again will skip to the previous track.

### Notes

- The built-in CD player plays one, standard, 12-cm or 8-cm (single) CD at a time. Do not use an adapter when playing 8-cm CDs.
- Do not insert anything other than a CD into the CD loading slot.
- When CD TEXT disc is inserted,  lights.
- If you cannot insert a disc completely or if after you insert a disc the disc does not play, check that the label side of the disc is up. Press **EJECT** to eject the disc, and check the disc for damage before inserting the disc again.
- ▲ and ▼ are used at the time of MP3 playback.
- If the built-in CD player does not operate properly, an error message such as **ERROR-11** may be displayed. Refer to *Understanding built-in CD player error messages* on page 45. 

## Built-in CD Player

### Introduction of advanced built-in CD player operation

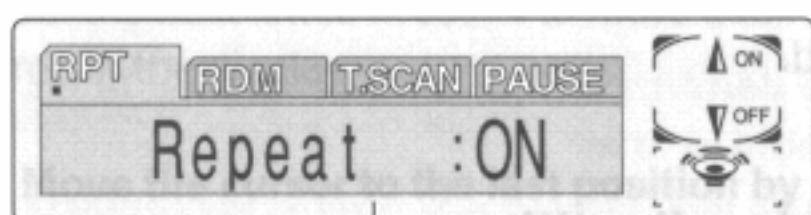

#### ① FUNCTION display

Shows the function status.

#### Press FUNCTION to display the function names.

Press **FUNCTION** repeatedly to switch between the following functions:

**RPT** (repeat play)—**RDM** (random play)—**T.SCAN** (scan play)—**PAUSE** (pause)

- To return to the playback display, press **BAND/ESC**.

#### Note

- If you do not operate the function within about 30 seconds, the display is automatically returned to the playback display.

### Repeating play

Repeat play lets you hear the same track over again.

#### 1 Press FUNCTION to select RPT.

Press **FUNCTION** until **Repeat** appears in the display.

#### 2 Press ▲ to turn repeat play on.

**Repeat :ON** appears in the display. The track presently playing will play and then repeat.

#### 3 Press ▼ to turn repeat play off.

**Repeat :OFF** appears in the display. The track presently playing will continue to play and then play the next track.

#### Note

- If you perform track search or fast forward/reverse, repeat play is automatically cancelled.

### Playing tracks in a random order

Random play lets you play back tracks on the CD in a random order.

#### 1 Press FUNCTION to select RDM.

Press **FUNCTION** until **Random** appears in the display.

#### 2 Press ▲ to turn random play on.

**Random :ON** appears in the display. Tracks will play in a random order.

#### 3 Press ▼ to turn random play off.

**Random :OFF** appears in the display. Tracks will continue to play in order.



## Scanning tracks of a CD

Scan play lets you hear the first 10 seconds of each track on the CD.

### 1 Press **FUNCTION** to select **T.SCAN**.

Press **FUNCTION** until **Track Scan** appears in the display.

### 2 Press **▲** to turn scan play on.

**Track Scan :ON** appears in the display. The first 10 seconds of each track is played.

### 3 When you find the desired track press **▼** to turn scan play off.

**Track Scan :OFF** appears in the display. The track will continue to play.

- If the display has automatically returned to the playback display, select **T.SCAN** again by pressing **FUNCTION**.



#### Note

- After scanning of a CD is finished, normal playback of the tracks will begin again.

## Pausing CD playback

Pause lets you temporarily stop playback of the CD.

### 1 Press **FUNCTION** to select **PAUSE**.

Press **FUNCTION** until **Pause** appears in the display.

### 2 Press **▲** to turn pause on.

**Pause :ON** appears in the display. Play of the current track pauses.

### 3 Press **▼** to turn pause off.

**Pause :OFF** appears in the display. Play will resume at the same point that you turned pause on.

## Using disc title functions

You can input CD titles and display the title. The next time you insert a CD for which you have entered a title, the title of that CD will be displayed.

### Entering disc titles

Disc title input lets you input CD titles up to 10 letters long and up to 48 disc titles into the built-in CD player.

### 1 Play a CD that you want to enter the title.

### 2 Press **FUNCTION** and hold until **TITLE** appears in the display.

- When playing a CD TEXT disc, you cannot switch to **TITLE**. The disc title will have already been recorded on a CD TEXT disc.

### 3 Press 1 numbered button to select the desired character type.

Press 1 numbered button repeatedly to switch between the following character type:

**Alphabet** (upper case), **Numbers** and **Symbols**—**Alphabet** (lower case)

- You can select to input Numbers and Symbols by pressing 2 numbered button.

### 4 Press **▲** or **▼** to select a letter of the alphabet.

Each press of **▲** will display a letter of the alphabet in **A B C ... X Y Z**, numbers and symbols in **1 2 3 ... @ # <** order. Each press of **▼** will display a letter in the reverse order, such as **Z Y X ... C B A** order.

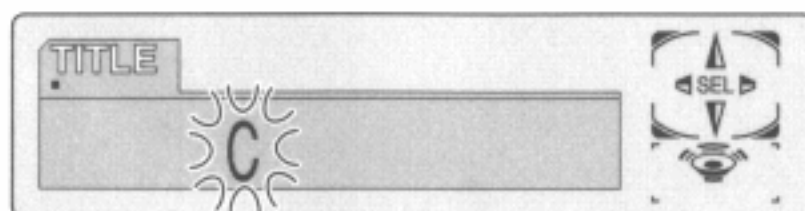

## Built-in CD Player

### 5 Press ► to move the cursor to the next character position.

When the letter you want is displayed, press ► to move the cursor to the next position and then select the next letter. Press ◀ to move backwards in the display.

### 6 Move the cursor to the last position by pressing ► after entering the title.

When you press ► one more time, the entered title is stored in memory.

### 7 Press BAND/ESC to return to the playback display.



#### Notes

- Titles remain in memory, even after the disc has been removed from built-in CD player, and are recalled when the disc is reinserted.
- After data for 48 discs has been stored in memory, data for a new disc will overwrite the oldest one.
- If you connect a multi-CD player, you can input disc titles for up to 100 discs.
- When a multi-CD player that does not support disc title function is connected, you cannot enter disc titles in this unit.

## Displaying disc titles

You can display the title of any disc that has had a disc title entered.

### Press DISPLAY.

Press **DISPLAY** repeatedly to switch between the following settings:

**PLAYBACK MODE** (play time)—**Disc Title** (disc title)

When you select **Disc Title**, the title of the currently playing disc is shown in the display.

- If no title has been entered for the currently playing disc, **NO TITLE** is displayed. ◻

## Using CD TEXT functions

Some discs have certain information encoded on the disc during manufacture. These discs may contain such information as the CD title, track title, artist's name and playback time and are called CD TEXT discs. Only these specially encoded CD TEXT discs support the functions listed below.

### Displaying titles on CD TEXT discs

#### Press DISPLAY when playing a CD TEXT disc.

Press **DISPLAY** repeatedly to switch between the following settings:

**PLAYBACK MODE** (play time)—**Disc Title** (disc title)—**Disc Artist Name** (disc artist name)—**Track Title** (track title)—**T-Artist Name** (track artist name)

- If specific information has not been recorded on a CD TEXT disc, **NO XXXX** will be displayed (e.g., **NO Track Title**).

### Scrolling titles in the display

This unit can display the first 16 letters only of **Disc Title**, **Disc Artist Name**, **Track Title** and **T-Artist Name**. When the recorded information is longer than 16 letters, you can scroll the text to the left so that the rest of the title can be seen.

#### Press DISPLAY and hold until the title begins to scroll to the left.

The rest of the title will appear in the display. ◻

## Playing a MP3

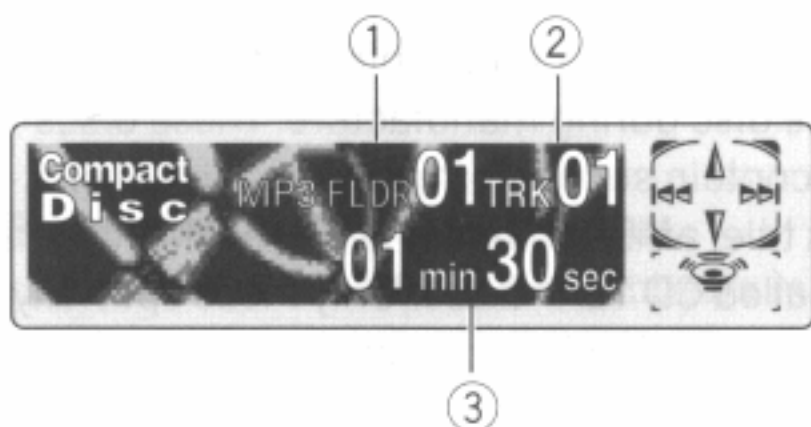

These are the basic steps necessary to play a MP3 with your built-in CD player. More advanced MP3 operation is explained starting on page 21.

- ① **FOLDER NUMBER indicator**  
Shows the folder number currently playing.
- ② **TRACK NUMBER indicator**  
Shows the track (file) currently playing.
- ③ **PLAY TIME indicator**  
Shows the elapsed playing time of the current track (file).

### 1 Press OPEN to open the front panel.

CD loading slot appears.

- After inserting a CD-ROM, press **SOURCE** to select the built-in CD player.

### 2 Insert a CD-ROM into the CD loading slot.

Playback will automatically start.

CD loading slot

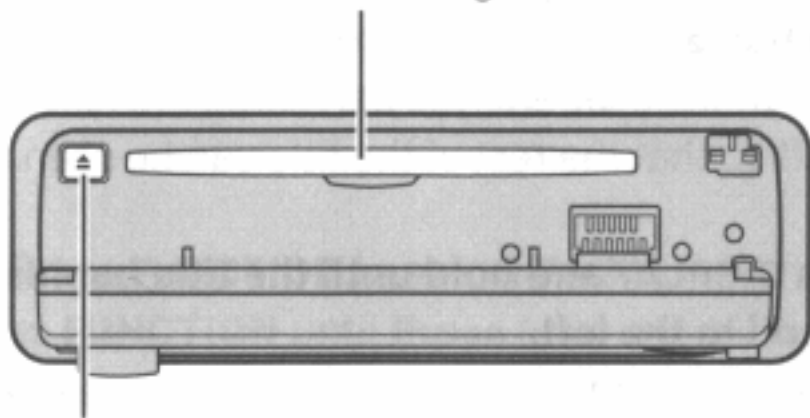

### EJECT button

- You can eject a CD-ROM by pressing **EJECT**.
- To avoid a malfunction, make sure that no metal object comes into contact with the terminals when the front panel is open.

### 3 After a CD-ROM has been inserted, close the front panel.

### 4 Use VOLUME to adjust the sound level.

Rotate to increase or decrease the volume.

### 5 Press ▲ or ▼ to select a folder.

- You can not select a folder that does not have an MP3 file recorded in it.
- Press ▼ for 2 seconds or longer to return to folder 01 (ROOT).

### 6 To perform fast forward or reverse, press and hold ◀ or ▶.

- This is fast forward and reverse operation only for the file being played. This operation is canceled when the previous or next file is reached.

### 7 To skip back or forward to another track, press ◀ or ▶.

Pressing ▶ skips to the start of the next track.

Pressing ◀ once skips to the start of the current track. Pressing again will skip to the previous track.

## Notes

- The built-in CD player can play back an MP3 file recorded on CD-ROM (Please refer to page 46 for files that can be played back.)
- Do not insert anything other than a CD into the CD loading slot.
- When a CD-ROM containing ID3 is inserted,  lights.
- There is sometimes a delay between starting up playback and the sound being issued. This is particularly the case when playing back multi-session and many folders. When being read in, **Format Read** is displayed.
- If you cannot insert a disc completely or if after you insert a disc the disc does not play, check that the label side of the disc is up. Press **EJECT** to eject the disc, and check the disc for damage before inserting the disc again.
- Playback is carried out in order of file number. Folders are skipped if they contain no files. (If folder 01 (ROOT) contains no files, playback commences with folder 02.)
- When playing back files recorded as VBR (Variable Bit Rate) files, the play time will not be correctly displayed if fast-forward or reverse operations are used.

## MP3 Player

- If selected disc contains no files that can be played back, **No Audio** is displayed.
- There is no sound on fast-forward or reverse.
- If the built-in CD player does not operate properly, an error message such as **ERROR-11** may be displayed. Refer to *Understanding built-in CD player error messages* on page 45.

### Introduction of advanced built-in CD player (MP3) operation



#### ① FUNCTION display

Shows the function status.

#### Press FUNCTION to display the function names.

Press **FUNCTION** repeatedly to switch between the following functions:

**PMODE** (repeat play)—**RDM** (random play)—**SCAN** (scan play)—**PAUSE** (pause)

- To return to the playback display, press **BAND/ESC**.

#### Note

- If you do not operate the function within about 30 seconds, the display is automatically returned to the playback display.

### Repeating play

For MP3 playback, there are three repeat play ranges: **FOLDER** (folder repeat), **TRK** (one-track repeat), and **DISC** (repeat all tracks).

#### 1 Press FUNCTION to select PMODE.

Press **FUNCTION** until **Repeat** appears in the display.

#### 2 Press ◀ or ▶ to select the repeat range.

Press ◀ or ▶ until the desired repeat range appears in the display.

- **FOLDER** – the folder being played back is repeated.
- **TRK** – the track being played back is repeated.
- **DISC** – the entire folder is repeated.



#### Notes

- If you select other folder during repeat play, the repeat play range changes to **DISC** (disc repeat).
- If you perform track search or fast forward/reverse during **TRK** (one-track repeat), the repeat play range changes to **FOLDER** (folder repeat).
- When **FOLDER** is selected, it is not possible to play back a sub-folder of that folder.



## Playing tracks in a random order

Random play lets you play back tracks in a random order within the repeat range, **F.RANDOM** (folder repeat) and **RANDOM** (disc repeat).

### 1 Select the repeat range.

Refer to *Repeating play* on page 21.

### 2 Press **FUNCTION** to select **RDM**.

Press **FUNCTION** until **Random** appears in the display.

### 3 Press **▲** to turn random play on.

**Random :ON** appears in the display. Tracks will play in a random order within the previously selected **F.RANDOM** (folder repeat) or **RANDOM** (disc repeat) ranges.

### 4 Press **▼** to turn random play off.

**Random :OFF** appears in the display. Tracks will continue to play in order.



#### Notes

- During random playback, only tracks (MP3 files) in the folder being played back will be played back. Tracks in the subfolder will not be played back.
- When the playback range is set to disc repeat, tracks of all folders will be played back in a random order.

## Scanning folders and tracks

While you are using **T.SCAN** (folder repeat), the beginning of each track in the selected folder plays for about 10 seconds. When you are using **F.SCAN** (disc repeat), the beginning of the first track of each folder is played for about 10 seconds.

### 1 Select the repeat range.

Refer to *Repeating play* on page 21.

### 2 Press **FUNCTION** to select **SCAN**.

Press **FUNCTION** until **Scan** appears in the display.

### 3 Press **▲** to turn scan play on.

**Scan :ON** appears in the display. The first 10 seconds of each track of the present folder (or the first track of each folder) is played.

### 4 When you find the desired track (or folder) press **▼** to turn scan play off.

**Scan :OFF** appears in the display. The track (or folder) will continue to play.

- If the display has automatically returned to the playback display, select **SCAN** again by pressing **FUNCTION**.



#### Notes

- Scan playback is cancelled if it returns to the track (or folder) where it started.
- During track repeat, if scan repeat is set to on, the playback range changes to folder repeat, and track scan is repeated.

## MP3 Player

### Pausing MP3 playback

Pause lets you temporarily stop playback of the MP3.

#### 1 Press **FUNCTION** to select **PAUSE**.

Press **FUNCTION** until **Pause** appears in the display.

#### 2 Press **▲** to turn pause on.

**Pause :ON** appears in the display. Play of the current track pauses.

#### 3 Press **▼** to turn pause off.

**Pause :OFF** appears in the display. Play will resume at the same point that you turned pause on.

### Displaying titles on MP3 disc

#### Press **DISPLAY** when playing a MP3 disc.

Press **DISPLAY** repeatedly to switch between the following settings:

**PLAYBACK MODE** (play time)—**Folder Name** (folder name)—**File Name** (file name)—**Track Title** (track title)—**Artist Name** (artist name)—**Album Title** (album title)—**BIT RATE** (bit rate)

- When playing back files recorded as VBR (Variable Bit Rate) files, the **BIT RATE** value is not displayed even after switching to **BIT RATE**.
- If specific information has not been recorded on a MP3 disc, **no xxxx** will be displayed (e.g., **no artist**).

### Scrolling titles in the display

This unit can display the first 16 letters only of **Folder Name**, **File Name**, **Track Title**, **Artist Name** and **Album Title**. When the recorded information is longer than 16 letters, you can scroll the text to the left so that the rest of the title can be seen.

#### Press **DISPLAY** and hold until the title begins to scroll to the left.

The rest of the title will appear in the display.

## Playing a CD

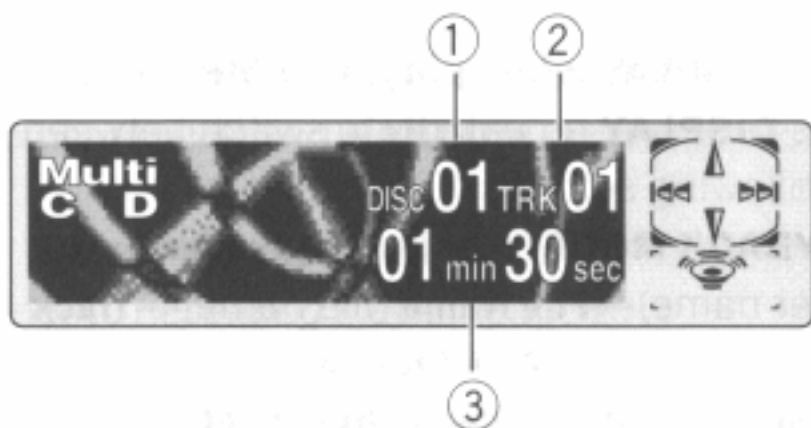

You can use this unit to control a multi-CD player, which is sold separately.

These are the basic steps necessary to play a CD with your multi-CD player. More advanced CD operation is explained starting on page 25.

### ① DISC NUMBER indicator

Shows the disc currently playing.

### ② TRACK NUMBER indicator

Shows the track currently playing.

### ③ PLAY TIME indicator

Shows the elapsed playing time of the current track.

## 1 Press SOURCE to select the multi-CD player.

Press **SOURCE** until you see **Multi-CD** displayed.

## 2 Use VOLUME to adjust the sound level.

Rotate to increase or decrease the volume.

## 3 Select a disc you want to listen to with the 1 to 6 buttons.

For discs located at 1 to 6, press the corresponding number button.

If you want to select a disc located at 7 to 12, press and hold the corresponding numbers such as **1** for disc 7, until the disc number appears in the display.

- You can also sequentially select a disc by pressing **▲/▼**.

4 To perform fast forward or reverse, press and hold **◀** or **▶**.

5 To skip back or forward to another track, press **◀** or **▶**.

Pressing **▶** skips to the start of the next track. Pressing **◀** once skips to the start of the current track. Pressing again will skip to the previous track.

## Notes

- When the multi-CD player performs the preparatory operations, **Ready** is displayed.
- If the multi-CD player does not operate properly, an error message such as **ERROR-11** may be displayed. Refer to the multi-CD player owner's manual.
- If there are no discs in the multi-CD player magazine, **NO DISC** is displayed.

## 50-disc multi-CD player

Only those functions described in this manual are supported for 50-disc multi-CD players.

## Multi-CD Player

### Introduction of advanced multi-CD player operation

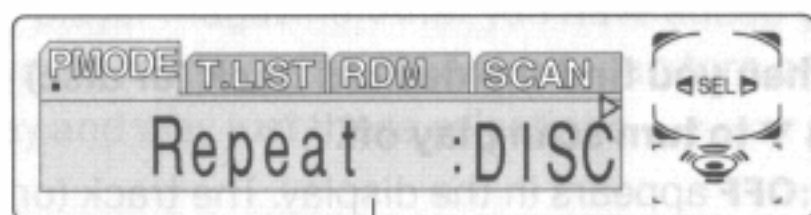

#### ① FUNCTION display

Shows the function status.

#### Press FUNCTION to display the function names.

Press **FUNCTION** repeatedly to switch between the following functions:

**P.MODE** (repeat play)—**T.LIST** (disc title list)—**RDM** (random play)—**SCAN** (scan play)—**ITS-P** (ITS play)—**PAUSE** (pause)—**COMP** (compression and DBE)

- To return to the playback display, press **BAND/ESC**.

#### Note

- If you do not operate the function within about 30 seconds, the display is automatically returned to the playback display.

### Repeating play

There are three repeat play ranges for the multi-CD player: **MCD** (multi-CD player repeat), **TRK** (one-track repeat), and **DISC** (disc repeat).

#### 1 Press FUNCTION to select P.MODE.

Press **FUNCTION** until **Repeat** appears in the display.

#### 2 Press ◀ or ▶ to select the repeat range.

Press ◀ or ▶ until the desired repeat range appears in the display.

- **MCD** — Repeat all discs in the multi-CD player
- **TRK** — Repeat just the current track
- **DISC** — Repeat the current disc

#### Notes

- If you select other discs during repeat play, the repeat play range changes to **MCD** (multi-CD player repeat).
- If you perform track search or fast forward/reverse during **TRK** (one-track repeat), the repeat play range changes to **DISC** (disc repeat).



## Playing tracks in a random order

Random play lets you play back tracks in a random order within the repeat range, **RANDOM** (multi-CD player repeat) and **D.RANDOM** (disc repeat).

### 1 Select the repeat range.

Refer to *Repeating play* on page 25.

### 2 Press FUNCTION to select RDM.

Press **FUNCTION** until **Random** appears in the display.

### 3 Press ▲ to turn random play on.

**Random :ON** appears in the display. Tracks will play in a random order within the previously selected **RANDOM** (multi-CD player repeat) or **D.RANDOM** (disc repeat) ranges.

### 4 Press ▼ to turn random play off.

**Random :OFF** appears in the display. Tracks will continue to play in order.

## Scanning CDs and tracks

While you are using **T.SCAN** (disc repeat), the beginning of each track on the selected disc plays for about 10 seconds. When you are using **D.SCAN** (multi-CD player repeat), the beginning of the first track of each disc is played for about 10 seconds.

### 1 Select the repeat range.

Refer to *Repeating play* on page 25.

### 2 Press FUNCTION to select SCAN.

Press **FUNCTION** until **Scan** appears in the display.

### 3 Press ▲ to turn scan play on.

**Scan :ON** appears in the display. The first 10 seconds of each track of the present disc (or the first track of each disc) is played.

### 4 When you find the desired track (or disc) press ▼ to turn scan play off.

**Scan :OFF** appears in the display. The track (or disc) will continue to play.

- If the display has automatically returned to the playback display, select **SCAN** again by pressing **FUNCTION**.



#### Note

- After track or disc scanning is finished, normal playback of the tracks will begin again.



## Pausing CD playback

Pause lets you temporarily stop playback of the CD.

### 1 Press FUNCTION to select PAUSE.

Press **FUNCTION** until **Pause** appears in the display.

### 2 Press ▲ to turn pause on.

**Pause :ON** appears in the display. Play of the current track pauses.

### 3 Press ▼ to turn pause off.

**Pause :OFF** appears in the display. Play will resume at the same point that you turned pause on.

## Multi-CD Player

### Using ITS playlists

ITS (instant track selection) lets you make a playlist of favorite tracks from those in the multi-CD player magazine. After you have added your favorite tracks to the playlist you can turn on ITS play and play just those selections.

### Creating a playlist with ITS programming

You can use ITS to enter and playback up to 99 tracks per disc, up to 100 discs (with the disc title). (With multi-CD players sold before the CDX-P1250 and CDX-P650, up to 24 tracks can be stored in the playlist.)

#### 1 Play a CD that you want to program.

Press **▲** or **▼** to select a CD.

#### 2 Press **FUNCTION** and hold until **TITLE** appears in the display, then press **FUNCTION** to select ITS.

After **TITLE** is displayed, press **FUNCTION** repeatedly, the following functions appear in the display:

**TITLE** (disc title input)—**ITS** (ITS programming)

#### 3 Select a desired track by pressing **◀** or **▶**.

#### 4 Press **▲** to store the currently playing track in the playlist.

**ITS Input** is displayed briefly and the currently playing selection is added to your playlist. The display then shows **ITS** again.

#### 5 Press **BAND/ESC** to return to the playback display.



#### Note

- After data for 100 discs has been stored in memory, data for a new disc will overwrite the oldest one.

### Playback from your ITS playlist

ITS play lets you listen to the tracks that you have entered into your ITS playlist. When you turn on ITS play, tracks from your ITS playlist in the multi-CD player will begin to play.

#### 1 Select the repeat range.

Refer to *Repeating play* on page 25.

#### 2 Press **FUNCTION** to select ITS-P.

Press **FUNCTION** until **ITS Play** appears in the display.

#### 3 Press **▲** to turn ITS play on.

**ITS Play :ON** appears in the display. Playback begins of those tracks from your playlist within the previously selected **MCD** (multi-CD player repeat) or **DISC** (disc repeat) ranges.

- If no tracks in the current range are programmed for ITS play then **ITS Empty** is displayed.

#### 4 Press **▼** to turn ITS play off.

**ITS Play :OFF** appears in the display. Playback will continue in normal order from the currently playing track and CD.

### Erasing a track from your ITS playlist

When you want to delete a track from your ITS playlist, you can if ITS play is on.

If ITS play is already on, skip to step 2. If ITS play is not already on, press **FUNCTION**.

#### 1 Play a CD you want to delete a track from your ITS playlist, and turn ITS play on.

Refer to *Playback from your ITS playlist* on page 27.

#### 2 Press **FUNCTION** and hold until **TITLE** appears in the display, then press **FUNCTION** to select **ITS**.

After **TITLE** is displayed, press **FUNCTION** until **ITS** appears in the display.

#### 3 Select a desired track by pressing ◀ or ▶.

#### 4 Press ▼ to erase a track from your ITS playlist.

The currently playing selection is erased from your ITS playlist and playback of the next track from your ITS playlist begins.

- If there are no tracks from your playlist in the current range, **ITS Empty** is displayed and normal play resumes.

#### 5 Press **BAND/ESC** to return to the playback display.

### Erasing a CD from your ITS playlist

When you want to delete all tracks of a CD from your ITS playlist, you can if ITS play is off.

#### 1 Play a CD that you want to delete.

Press ▲ or ▼ to select a CD.

#### 2 Press **FUNCTION** and hold until **TITLE** appears in the display, then press **FUNCTION** to select **ITS**.

After **TITLE** is displayed, press **FUNCTION** until **ITS** appears in the display.

#### 3 Press ▼ to erase all tracks on the currently playing CD from your ITS playlist.

All tracks on the currently playing CD are erased from your playlist and **ITS Clear** is displayed.

#### 4 Press **BAND/ESC** to return to the playback display. ◻

## Using disc title functions

You can input CD titles and display the title. Then you can easily search for and select a desired disc for play.

### Entering disc titles

Disc title input lets you input CD titles up to 10 letters long and up to 100 disc titles (with ITS playlist) into the multi-CD player.

#### 1 Play a CD that you want to enter the title.

Press ▲ or ▼ to select a CD.

#### 2 Press **FUNCTION** and hold until **TITLE** appears in the display.

After **TITLE** is displayed, press **FUNCTION** repeatedly, the following functions appear in the display:

**TITLE** (disc title input)—**ITS** (ITS programming)

- When playing a CD TEXT disc on a CD TEXT compatible multi-CD player, you cannot switch to **TITLE**. The disc title will have already been recorded on a CD TEXT disc.

## Multi-CD Player

### 3 Press 1 numbered button to select the desired character type.

Press **1** numbered button repeatedly to switch between the following character type:

**Alphabet** (Upper case), **Numbers** and **Symbols**—**Alphabet** (Lower case)

- You can select to input Numbers and Symbols by pressing **2** numbered button.

### 4 Press ▲ or ▼ to select a letter of the alphabet.

Each press of ▲ will display a letter of the alphabet in **A B C ... X Y Z**, numbers and symbols in **1 2 3 ... @ # < order**. Each press of ▼ will display a letter in the reverse order, such as **Z Y X ... C B A** order.

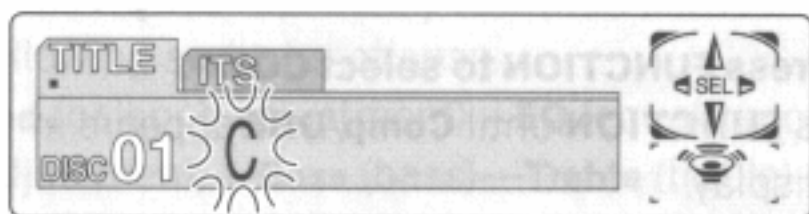

### 5 Press ► to move the cursor to the next character position.

When the letter you want is displayed, press ► to move the cursor to the next position and then select the next letter. Press ◀ to move backwards in the display.

### 6 Move the cursor to the last position by pressing ► after entering the title.

When you press ► one more time, the entered title is stored in memory.

### 7 Press BAND/ESC to return to the playback display.



#### Notes

- Titles remain in memory, even after the disc has been removed from the magazine, and are recalled when the disc is reinserted.
- After data for 100 discs has been stored in memory, data for a new disc will overwrite the oldest one.

## Displaying disc titles

You can display the title of any disc that has had a disc title entered.

### Press DISPLAY.

Press **DISPLAY** repeatedly to switch between the following settings:

**PLAYBACK MODE** (play time)—**Disc Title** (disc title)

When you select **Disc Title**, the title of the currently playing disc is shown in the display.

- If no title has been entered for the currently playing disc, **NO TITLE** is displayed.

## Selecting discs from the disc title list

Disc title list lets you see the list of disc titles that have been entered into the multi-CD player and select one of them to playback.

### 1 Press FUNCTION to select T.LIST.

Press **FUNCTION** until disc title appears in the display.

### 2 Press ◀ or ► to scroll through the list of titles that have been entered.

- If no title has been entered for a disc, **NO D-TITLE** will be displayed.

### 3 Press ▲ to play your favorite CD title.

That selection will begin to play. 



## Using CD TEXT functions

*You can use these functions only with a CD TEXT compatible multi-CD player.*

Some discs have certain information encoded on the disc during manufacture. These discs may contain such information as the CD title, track title, artist's name and playback time and are called CD TEXT discs. Only these specially encoded CD TEXT discs support the functions listed below.

### Displaying titles on CD TEXT discs

**Press DISPLAY when playing a CD TEXT disc from the multi-CD player.**

Press **DISPLAY** repeatedly to switch between the following settings:

**PLAYBACK MODE** (play time)—**Disc Title** (disc title)—**Disc Artist Name** (disc artist name)—**Track Title** (track title)—**T-Artist Name** (track artist name)

- If specific information has not been recorded on a CD TEXT disc, **NO XXXX** will be displayed (e.g., **NO Track Title**).

### Scrolling titles in the display

This unit can display the first 16 letters only of **Disc Title**, **Disc Artist Name**, **Track Title** and **T-Artist Name**. When the recorded information is longer than 16 letters, you can scroll the text to the left so that the rest of the title can be seen.

**Press DISPLAY and hold until the title begins to scroll to the left.**

The rest of the title will appear in the display.

## Using compression and bass emphasis

*You can use these functions only with a multi-CD player that supports them.*

Using COMP (compression) and DBE (dynamic bass emphasis) functions let you adjust the sound playback quality of the multi-CD player. Each of the functions have a two-step adjustment. The COMP function balances the output of louder and softer sounds at higher volumes. DBE boosts bass levels to give playback a fuller sound. Listen to each of the effects as you select through them and use the one that best enhances the playback of the track or CD that you are listening to.

### 1 Press FUNCTION to select COMP.

Press **FUNCTION** until **Comp/DBE** appears in the display.

- If the multi-CD player does not support COMP/DBE, **No Comp** is displayed when you attempt to select it.

### 2 Press ▲ or ▼ to select your favorite setting.

Press **▲** or **▼** repeatedly to switch between the following settings:

**Comp OFF—Comp 1—Comp 2—Comp OFF—DBE 1—DBE 2**

## Audio Adjustments

### Introduction of audio adjustments

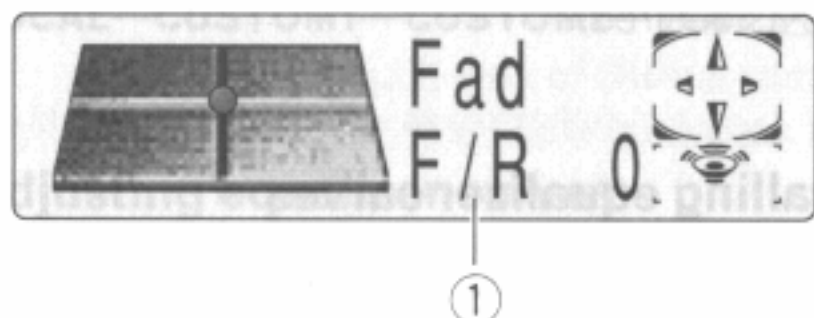

#### ① AUDIO display

Shows the audio adjustments status.

#### Press **AUDIO** to display the audio function names.

Press **AUDIO** repeatedly to switch between the following audio functions:

**Fad** (balance adjustment)—**EQ** (equalizer curve adjustment)—**Bass** (bass)—**Treble** (treble)—**Loud** (loudness)—**Sub-W1** (subwoofer1)/**Non Fad** (non fading output on/off)—**Sub-W2** (subwoofer2)/**Non Fad** (non fading output setting)—**HPF** (high pass filter)—**SLA** (source level adjustment)

- When the subwoofer controller setting is only **S.W Control:EXT**, you cannot switch the **Sub-W1**. (Refer to page 38.)
- You can select the **Sub-W2** only when Subwoofer output is switched on in the **Sub-W1**.
- When the subwoofer controller setting is only **S.W Control:EXT**, you can switch the non fading output on/off mode. (Refer to page 38.)
- You can select the non fading output setting mode only when non fading output is switched on in the non fading output on/off mode.
- When selecting the FM tuner as the source, you cannot switch to **SLA**.
- To return to the playback display, press **BAND/ESC**.

#### Note

- If you do not operate the audio function within about 30 seconds, the display is automatically returned to the source display. 

### Setting the sound focus equalizer

Clarifying the sound image of vocals and instruments allows the simple staging of a natural, pleasant sound environment.

Even greater listening enjoyment will be obtained if seating positions are chosen carefully.

- **FRT1** boosts the treble on the front output and the bass on the rear output.

**FRT2** boosts the treble and the bass on the front output and the bass on the rear output. (The bass boost is the same for both front and rear.) For both **FRT1** and **FRT2** the **H** setting provides a more pronounced effect than the **L** setting.

#### 1 Press **SFEQ** to select the desired **SFEQ** mode.

**FRT1-H** (front1-high) —**FRT1-L** (front1-low) —  
**FRT2-H** (front2-high) —**FRT2-L** (front2-low) —  
**CUSTOM** (custom) —**SFEQ OFF** (off)

#### 2 Press **◀** or **▶** to select the desired position.

Press **◀** or **▶** until the desired position appears in the display.

**LEFT** (left) —**CENTER** (center) —**RIGHT** (right)

#### Notes

- If you adjust the bass or treble, **CUSTOM** memorizes an **SFEQ** mode in which the bass and treble are adjusted for personal preference.

- If you switch the **SFEQ** mode, the **H.P.F.** function is automatically switched off. By switching the **H.P.F.** function on after selecting the **SFEQ** mode, you can combine **H.P.F.** function with **SFEQ** function.

## Using balance adjustment

You can select a fader/balance setting that provides an ideal listening environment in all occupied seats.

### 1 Press **AUDIO** to select **Fad**.

Press **AUDIO** until **Fad** appears in the display.

- If the balance setting has been previously adjusted, **Bal** will be displayed.

### 2 Press **▲** or **▼** to adjust front/rear speaker balance.

Each press of **▲** or **▼** moves the front/rear speaker balance towards the front or the rear.

- **Fad F15 – Fad R15** is displayed as the front/rear speaker balance moves from front to rear.
- **Fad 0** is the proper setting when only two speakers are used.
- When the rear output setting is **Rear SP:S.W.**, you cannot adjust front/rear speaker balance. Refer to *Setting the rear output and subwoofer controller* on page 38.

### 3 Press **◀** or **▶** to adjust left/right speaker balance.

When you press **◀** or **▶**, **Bal 0** is displayed. Each press of **◀** or **▶** moves the left/right speaker balance towards the left or the right.

- **Bal L9 – Bal R9** is displayed as the left/right speaker balance moves from left to right.

## Using the equalizer

The graphic equalizer lets you adjust the equalization to match car interior acoustic characteristics as desired.

### Recalling equalizer curves

There are seven stored equalizer curves which you can easily recall at any time. Here is a list of the equalizer curves:

Display	Equalizer curve
<b>SUPER BASS</b>	Super bass
<b>POWERFUL</b>	Powerful
<b>NATURAL</b>	Natural
<b>VOCAL</b>	Vocal
<b>CUSTOM1,2</b>	Custom1,2
<b>FLAT</b>	Flat

- **CUSTOM1** and **CUSTOM2** are adjusted equalizer curve.
- A separate **CUSTOM1** curve can be created for each source. (The Built-in CD player and Multi-CD player are set to the same Equalizer Curve Adjustment setting automatically.)
- If you make adjustments when a curve other than **CUSTOM2** is selected, the equalizer curve settings are memorized in **CUSTOM1**.
- A **CUSTOM2** curve can be created common to all sources.
- If you make adjustments when the **CUSTOM2** curve is selected, the **CUSTOM2** curve is updated.
- When **FLAT** is selected no supplement or correction is made to the sound. This is useful to check the effect of the equalizer curves by switching alternatively between **FLAT** and a set equalizer curve.

## Audio Adjustments

### 1 Press EQ to select the equalizer.

Press **EQ** repeatedly to switch between the following equalizer.

**SUPER BASS**—**POWERFUL**—**NATURAL**—**VOCAL**—**CUSTOM1**—**CUSTOM2**—**FLAT**

### Adjusting equalizer curves

You can adjust the currently selected equalizer curve setting as desired. Adjusted equalizer curve settings are memorized in **CUSTOM1** or **CUSTOM2**.

### 1 Press AUDIO to select the equalizer mode .

Press **AUDIO** until **EQ Low/EQ Mid/EQ High** appears in the display.

### 2 Select the equalizer band you want to adjust with $\leftarrow/\rightarrow$ .

**EQ Low** (low)—**EQ Mid** (mid)—**EQ High** (high)

### 3 Press $\blacktriangle$ or $\blacktriangledown$ to adjust the equalizer curve.

Each press of  $\blacktriangle$  or  $\blacktriangledown$  increases or decreases the equalizer curve respectively.

- **+6**—**-6** is displayed as the equalizer curve is increased or decreased.



#### Note

- If you make adjustments when a curve other than **CUSTOM2** is selected, **CUSTOM1** curve is updated.

### Fine adjusting equalizer curve

You can adjust the center frequency and the Q factor (curve characteristics) of each currently selected curve band (**EQ Low/EQ Mid/EQ High**).

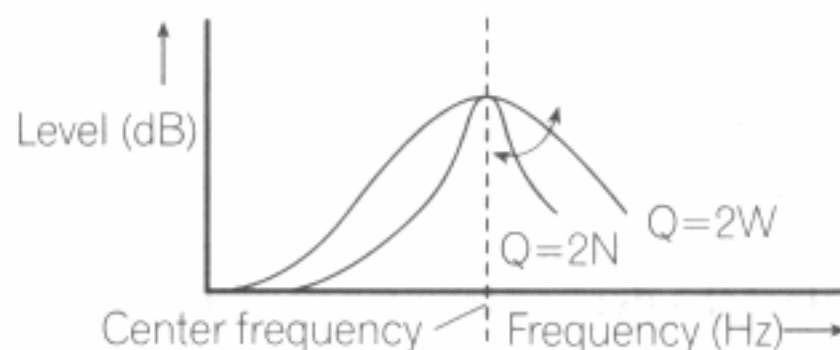

### 1 Press AUDIO and hold until frequency and the Q factor (e.g., F 80 Q 1W) appears in the display.

### 2 Press AUDIO to select the desired band for adjustment.

**LOW** (low)—**MID** (mid)—**HIGH** (high)

### 3 Select the desired frequency with $\leftarrow/\rightarrow$ .

Press  $\leftarrow$  or  $\rightarrow$  until the desired frequency appears in the display.

**LOW** : 40—80—100—160 (Hz)

**MID** : 200—500—1 k—2 k (Hz)

**HIGH** : 3.15 k—8 k—10 k—12.5 k (Hz)

### 4 Press $\blacktriangle/\blacktriangledown$ to select the desired Q factor.

Press  $\blacktriangle$  or  $\blacktriangledown$  until the desired Q factor appears in the display.

**2 N**—**1 N**—**1 W**—**2 W**



#### Note

- If you make adjustments when a curve other than **CUSTOM2** is selected, **CUSTOM1** curve is updated.



## Adjusting bass

You can adjust the cut-off frequency and the bass level.

- In **FRT1** mode, bass adjustment affects only the rear output: front output cannot be adjusted.

### 1 Press **AUDIO** to select **Bass**.

Press **AUDIO** until **Bass** appears in the display.

### 2 Select the desired frequency with **◀/▶**.

Press **◀** or **▶** until the desired frequency appears in the display.

**40—63—100—160** (Hz)

### 3 Press **▲** or **▼** to adjust the bass level.

Each press of **▲** or **▼** increases or decreases the bass level. **+6 – -6** is displayed as the level is increased or decreased.

## Adjusting treble

You can adjust the cut-off frequency and the Treble level.

- In **FRT1** and **FRT2** modes, treble adjustment affects only the front output: rear output cannot be adjusted.

### 1 Press **AUDIO** to select **Treble**.

Press **AUDIO** until **Treble** appears in the display.

### 2 Select the desired frequency with **◀/▶**.

Press **◀** or **▶** until the desired frequency appears in the display.

**2.5k—4k—6.3k—10k** (Hz)

### 3 Press **▲** or **▼** to adjust the treble level.

Each press of **▲** or **▼** increases or decreases the treble level. **+6 – -6** is displayed as the level is increased or decreased.

## Adjusting loudness

Loudness compensates for deficiencies in the low- and high-sound ranges at low volume.

### 1 Press **AUDIO** to select **Loud**.

Press **AUDIO** until **Loud** appears in the display.

### 2 Press **▲** to turn loudness on.

Loudness level (e.g., **Loud Mid**) appears in the display.

### 3 Press **◀** or **▶** to select the level.

Press **◀** or **▶** until the desired level appears in the display.

**Low** (low)—**Mid** (mid)—**High** (high)

### 4 Press **▼** to turn loudness off.

**Loud OFF** appears in the display.

## Using subwoofer output

This unit is equipped with a subwoofer output which can be switched on or off.

### 1 Press **AUDIO** to select **Sub-W1**.

When the subwoofer controller setting is **S.W Control:EXT**, you cannot select **Sub-W1**. Press **AUDIO** until **Sub-W1** appears in the display.

### 2 Press **▲** to turn subwoofer output on.

**Sub-W1 Normal** appears in the display.

Subwoofer output is now on.

- You can turn off subwoofer output by pressing **▼**.

### 3 Press **◀** or **▶** to select the phase of subwoofer output.

Press **◀** to select reverse phase and **Rev.**

appears in the display. Press **▶** to select normal phase and **Normal** appears in the display.

## Audio Adjustments

### Adjusting subwoofer settings

When the subwoofer output is on, you can adjust the cut-off frequency and the output level of the subwoofer.

#### 1 Press **AUDIO** to select the **Sub-W2**.

When the subwoofer output is on, you can select the **Sub-W2**. Press **AUDIO** until **Sub-W2 80** (Hz) appears in the display.

- If the subwoofer setting has been previously adjusted, the frequency of that previously selected will be displayed, such as **50** (Hz) or **125** (Hz).

#### 2 Press **◀** or **▶** to select cut-off frequency.

Press **◀** and **50** (Hz) is displayed. Press **▶** and **125** (Hz) is displayed. Only frequencies lower than those in the selected range are output from the subwoofer.

#### 3 Press **▲** or **▼** to adjust the output level of the subwoofer.

Each press of **▲** or **▼** increases or decreases the level of the subwoofer (e.g., **+6** to **-6**).

Press **▲** or **▼** until you see the desired value displayed.

### Using non fading output

When the non fading output setting is on, the audio signal does not pass through this unit's low pass filter (for the subwoofer), but is output through the RCA output.

#### 1 Press **AUDIO** to select non fading output on/off mode.

When the subwoofer controller setting is **S.W Control:EXT**, you can select non fading output on/off mode. Press **AUDIO** until **NonFad ON** appears in the display.

#### 2 Press **▲** to turn non fading output on.

**NonFad ON** appears in the display. non fading output is now on.

- You can turn off non fading output by pressing **▼**.

### Adjusting non fading output level

When the non fading output is on, you can adjust the level of non fading output.

#### 1 Press **AUDIO** to select non fading output setting mode.

Press **AUDIO** until **NonFad 0** appears in the display.

#### 2 Press **▲** or **▼** to adjust the output level of the non fading.

Each press of **▲** or **▼** increases or decreases the level of the non fading (e.g., **+6** to **-6**).

Press **▲** or **▼** until you see the desired value displayed.

## Using the high pass filter

When you do not want low sounds from the subwoofer output frequency range to play from the front or rear speakers, switch the HPF (high pass filter) on. Only frequencies higher than those in the selected range are output from the front and rear speakers.

### 1 Press **AUDIO** to select **HPF**.

Press **AUDIO** until **HPF** appears in the display.

### 2 Press **▲** to turn high pass filter on.

**HPF 80 Hz** appears in the display. High pass filter is now on.

- To turn high pass filter off, press **▼**.

### 3 Press **◀** or **▶** to select a high pass filter range.

Press **◀** and **HPF 50 Hz** is displayed. Press **▶** and **125 Hz** is displayed. Only frequencies higher than those in the selected range are output from the front or rear speakers.



#### Note

- If you switch the **SFEQ** mode, the **H.P.F.** function is automatically switched off. By switching the **H.P.F.** function on after selecting the **SFEQ** mode, you can combine **H.P.F.** function with **SFEQ** function.

## Adjusting source levels

SLA (Source level adjustment) lets you adjust the volume level of each source to prevent radical changes in volume when switching between sources.

- Settings are based on the volume level of the FM tuner, which remains unchanged.

### 1 Compare the FM tuner volume level with the level of the source you wish to adjust (e.g., built-in CD player).

### 2 Press **AUDIO** to select **SLA**.

Press **AUDIO** until **SLA** appears in the display.

### 3 Press **▲** or **▼** to adjust the source volume.

Each press of **▲** or **▼** increases or decreases the source volume.

- **SLA +4 – SLA –4** is displayed as the source volume is increased or decreased.



#### Notes

- Since the FM tuner volume is the control, it is not possible to apply source level adjustments to the FM tuner.
- The AM tuner volume level can also be adjusted with source level adjustments.
- The built-in CD and the multi-CD players are both set to the same source level adjustment volume automatically.
- External unit 1 and External unit 2 are set to the same volume adjustment setting automatically.

## Initial Settings

### Adjusting initial settings

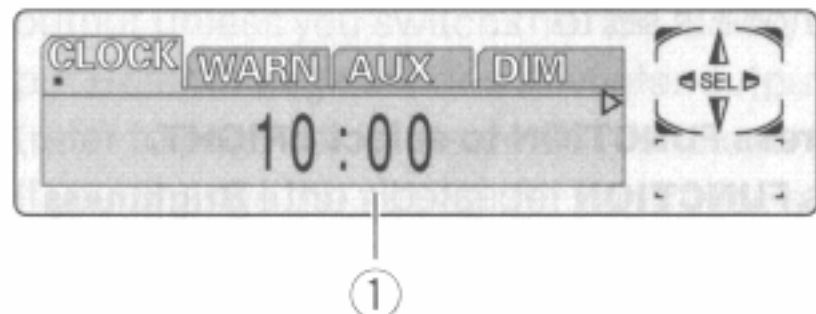

Initial settings lets you perform initial set up of different settings for this unit.

#### ① FUNCTION display

Shows the function status.

**1 Press SOURCE and hold until the unit turns off.**

**2 Press FUNCTION and hold until time appears in the display.**

**3 Press FUNCTION to select one of the initial settings.**

Press **FUNCTION** repeatedly to switch between the following settings:

**CLOCK—WARN—AUX—DIM—BRIGHT—SW—TEL**

Use the following instructions to operate each particular setting.

- To cancel initial settings, press **BAND/ESC**.
- You can also cancel initial settings by holding down **FUNCTION** until the unit turns off.

### Setting the time

This is used to set the time on the unit's clock display.

**1 Press FUNCTION to select the CLOCK.**

Press **FUNCTION** until the time appears in the display.

**2 Select the portion of the time display you wish to set with ◀/▶.**

Pressing ◀/▶ will select a portion of the clock display:

**HOUR—MINUTE**

As you select portions of the clock display the portion selected will blink.



**3 Select the correct time with ▲/▼.**

Pressing ▲ will increase the selected hour or minute. Pressing ▼ will decrease the selected hour or minute.

### Switching the warning tone

If the front panel is not detached from the head unit within five seconds of turning off the ignition, a warning tone will sound. You can turn off this warning tone.

**1 Press FUNCTION to select WARN.**

Press **FUNCTION** repeatedly until **Warning** appears in the display.

**2 Select WARN on or off with ▲/▼.**

Pressing ▲/▼ will switch **Warning** between on and off and that status will be displayed (e.g., **Warning :ON**).



## Switching the auxiliary setting

It is possible to use auxiliary equipment with this unit. Activate the auxiliary setting when using auxiliary equipment connected to this unit.

### 1 Press **FUNCTION** to select **AUX**.

Press **FUNCTION** repeatedly until **AUX** appears in the display.

### 2 Select **AUX** on or off with **▲/▼**.

Pressing **▲/▼** will switch **AUX** between on and off and that status will be displayed (e.g., **AUX :ON**).

## Switching the dimmer setting

To prevent the display from being too bright at night, the display is automatically dimmed when the car's headlights are turned on. You can switch dimmer on or off.

### 1 Press **FUNCTION** to select **DIM**.

Press **FUNCTION** repeatedly until **Dimmer** appears in the display.

### 2 Select **DIM** on or off with **▲/▼**.

Pressing **▲/▼** will switch **Dimmer** between on and off and that status will be displayed (e.g., **Dimmer :ON**).

## Selecting the brightness

You can select the display brightness. Initially this mode is set to 12.

### 1 Press **FUNCTION** to select **BRIGHT**.

Press **FUNCTION** repeatedly until **Brightness** appears in the display.

### 2 Select the desired brightness with **◀/▶**.

- The display shows 0 – 15.

## Setting the rear output and subwoofer controller

This product's rear output (rear speaker leads output and RCA rear output) can be used for full-range speaker (**Rear SP:FULL**) or subwoofer (**Rear SP:S.W**) connection. If you switch rear output setting to the **Rear SP:S.W**, you can connect a rear speaker lead directly to a subwoofer without using an auxiliary amp.

Initially, the unit is set for rear full-range speaker connection (**Rear SP:FULL**).

When rear output are connected to full range speakers (when **Rear SP:FULL** is selected), you can connect the RCA subwoofer output to a subwoofer. In this case, you can select whether to use the subwoofer controller's (low pass filter, phase) built-in **S.W Control:INT** or the auxiliary **S.W Control:EXT**.

## Initial Settings



### Notes

- Even if you change this setting, there is no output unless you switch the non fading output (refer to page 35) or subwoofer output (refer to page 34) in the audio menu on.
- If you change the subwoofer controller, subwoofer output and non fading output in the audio menu return to the factory settings.
- Both rear speaker leads output and RCA rear output are switched simultaneously in this setting mode.

#### 1 Press FUNCTION to select SW.

Press **FUNCTION** repeatedly until **Rear SP** appears in the display.

#### 2 Change the rear output setting with ▲/▼.

Pressing ▲/▼ will switch between **Rear SP :FULL** (full-range speaker) and **Rear SP :S.W** (subwoofer) and that status will be displayed.



### Notes

- When no subwoofer is connected to the rear output, select **Rear SP:FULL**.
- When a subwoofer is connected to the rear output, set for subwoofer **Rear SP:S.W**.
- When the rear output setting is **Rear SP:S.W**, you cannot change the subwoofer controller.

#### 3 Change the subwoofer controller with ◀/▶.

Pressing ◀/▶ will switch between **S.W Control :INT** and **S.W Control :EXT** and that status will be displayed.

## Switching the Telephone Muting/Attenuation

Sound from this system is muted or attenuated automatically when a call is made or received using a cellular telephone connected to this product.

#### 1 Press FUNCTION to select TEL.

Press **FUNCTION** repeatedly until **Telephone** appears in the display.

#### 2 Switch the telephone muting/attenuation with ◀/▶.

Pressing ◀/▶ will switch between **Telephone :ATT** (attenuation) and **Telephone :MUTE** (muting) and that status will be displayed.

## Setting the time display on or off

You can display the clock on each sound source display.

### Press **CLOCK** to select the time display.

Each press of **CLOCK** turns time display on or off.

- The time display disappears temporarily when you perform other operations, but the time indication is displayed again after 6 seconds.



### Note

- Even when the sources and the feature demo are off, the time appears on the display. Pressing **CLOCK** switches the time display on/off.

## Using different entertainment displays

You can enjoy entertainment displays while listening to each sound source.

### Press **ENTERTAINMENT**.

Each time you press **ENTERTAINMENT** the display changes in the following order:

**SOURCE ICON DISPLAY—BGV 1—BGV 2—BGV 3—BGV 4—LEVEL INDICATOR 1—LEVEL INDICATOR 2—MOVIE SCREEN 1—MOVIE SCREEN 2—ENTERTAINMENT CLOCK**

- BGV stands for Back Ground Visual.

## Using the **AUX** source

An IP-BUS-RCA Interconnector such as the CD-RB20 or CD-RB10 (sold separately) lets you connect this unit to auxiliary equipment featuring RCA output. For more details, refer to the IP-BUS-RCA Interconnector owner's manual.

### Selecting **AUX** as the source

#### Press **SOURCE** to select **AUX** as the source.

Press **SOURCE** until **AUX** appears in the display.

- If the auxiliary setting is not switched on, **AUX** cannot be selected. For more details, see *Switching the auxiliary setting* on page 38.

### Setting the **AUX** title

The title displayed for the **AUX** source can be changed.

**1 After you have selected **AUX** as the source, press **FUNCTION** and hold until **TITLE** appears in the display.**

**2 Press 1 numbered button to select the desired character type.**

Press **1** numbered button repeatedly to switch between the following character type:

**Alphabet** (Upper case), **Numbers** and **Symbols—Alphabet** (Lower case)

- You can select to input Numbers and Symbols by pressing **2** numbered button.

## Other Functions

### 3 Press ▲ or ▼ to select a letter of the alphabet.

Each press of ▲ will display a letter of the alphabet in **A B C ... X Y Z**, numbers and symbols in **1 2 3 ... @ # <** order. Each press of ▼ will display a letter in the reverse order, such as **Z Y X ... C B A** order.

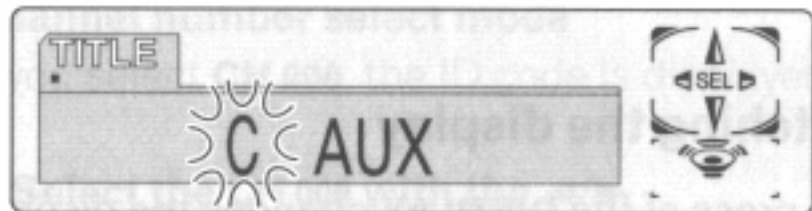

### 4 Press ► to move the cursor to the next character position.

When the letter you want is displayed, press ► to move the cursor to the next position and then select the next letter. Press ◀ to move backwards in the display.

### 5 Move the cursor to the last position by pressing ► after entering the title.

When you press ► one more time, the entered title is stored in memory.

### 6 Press BAND/ESC to return to the playback display. ◻

## Using the telephone muting/attenuation function

Sound from this system is muted or attenuated automatically when a call is made or received using a cellular telephone connected to this product.

- The sound is turned off, **MUTE** or **ATT** is displayed and no audio adjustment is possible.
- Operation returns to normal when the phone connection is ended. ◻



## Introduction of XM operation

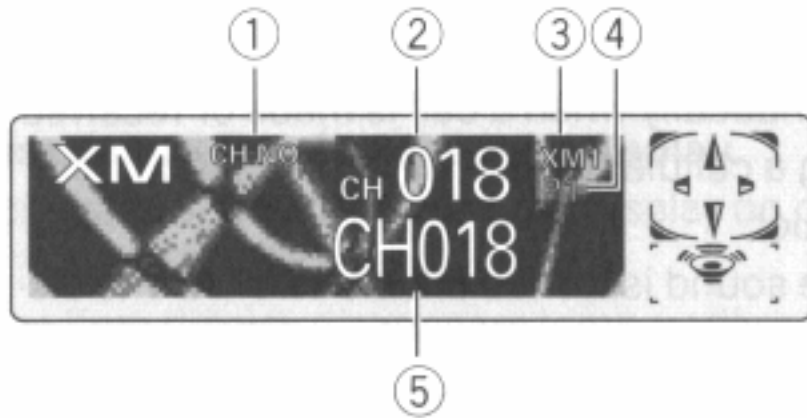

You can use this product with a separately sold Universal XM satellite digital tuner system (GEX-FM903XM) or XM satellite digital tuner (GEX-P900XM). For details concerning operation, refer to the XM tuner's operation manuals. This section provides information on XM operations with this product which differs from that described in the XM tuner's operation manual.

- ① **CHANNEL SELECT MODE indicator**  
Shows what channel select mode has been selected. **CH.NO** is displayed when **CH NUMBER** is selected, and **CAT** is displayed when **CATEGORY** is selected.
- ② **CHANNEL NUMBER indicator**  
Shows to which channel number the tuner is tuned.
- ③ **BAND indicator**  
Shows the band which has been selected.
- ④ **PRESET NUMBER indicator**  
Shows what preset has been selected.
- ⑤ **XM Tuner information**  
The display is switched each time **DISPLAY** is pressed.

## Operation

Operation of the following functions with this product differs.

- Switching the display (Refer to page 42.)
- Switching the channel select mode (Refer to page 42.)
- Display the ID code (Refer to page 43.)

### Switching the display

Each press of the **DISPLAY** changes the display in the following order:

**CHANNEL NUMBER—CHANNEL NAME—ARTIST NAME/FEATURE—SONG/PROGRAM TITLE—ADDITIONAL INFORMATION**

### Switching the channel select mode

You can switch if you select a Channel with a Channel Number or from a Channel Category when you select a channel.

**1 Press FUNCTION to select MODE.**

**2 Press ◀ or ▶ to select the desired channel select mode.**

**CH NUMBER** (Channel number select mode) — **CATEGORY** (Channel category select mode)

## Other Functions

### Display the ID Code

Each XM tuner is identified with a unique radio ID. You will need the radio ID when activating XM service or when reporting a problem. How to display the ID code depends on the channel select mode.

#### Channel number select mode

If you select **CH 000**, the ID code is displayed.

- Select the **CH 000** with the ◀/▶

#### Channel category select mode

**RADIO ID** is provided as a channel category for displaying the ID code.

- Select the Channel Category **RADIO ID** with the ▲/▼ buttons.
- If you select another channel, display of the ID code is canceled.
- Display of the ID code repeats displaying **RADIO ID** and the ID code one after the other.



## Additional Information

### CD player and care

- Use only CDs that have either of the two Compact Disc Digital Audio marks as show below.



- Use only normal, round CDs. If you insert irregular, non-round, shaped CDs they may jam in the CD player or not play properly.



- Check all CDs for cracks, scratches or warped discs before playing. CDs that have cracks, scratches or are warped may not play properly. Do not use such discs.
- Avoid touching the recorded (non-printed side) surface when handling the disc.
- Store discs in their cases when not in use.
- Keep discs out of direct sunlight and do not expose the discs to high temperatures.

- Do not attach labels, write on or apply chemicals to the surface of the discs.
- To clean dirt from a CD, wipe the disc with a soft cloth outward from the center of the disc.



- If the heater is used in cold weather, moisture may form on components inside the CD player. Condensation may cause the CD player to not operate properly. If you think that condensation is a problem turn off the CD player for an hour or so to allow the CD player to dry out and wipe any damp discs with a soft cloth to remove the moisture.
- Road shocks may interrupt CD playback.

## CD-R/CD-RW discs

- It may not be possible to play back CD-R/CD-RW discs recorded on a music CD recorder or a personal computer because of disc characteristics, scratches or dirt on the disc, or dirt, condensation, etc. on the lens of this unit.
- Playback of discs recorded on a personal computer may not be possible depending on the application settings and the environment. Please record with the correct format. (For details, contact the manufacturer of the application.)
- Playback of CD-R/CD-RW discs may become impossible in case of direct exposure to sunlight, high temperatures, or the storage conditions in the car.
- Titles and other text information recorded on a CD-R/CD-RW disc may not be displayed by this product (in the case of audio data (CD-DA)).
- This product conforms to the track skip function of the CD-R/CD-RW disc. The tracks containing the track skip information are skipped over automatically (in the case of audio data (CD-DA)).
- If you insert a CD-RW disc into this product, time to playback will be longer than when you insert a conventional CD or CD-R disc.
- Read the precautions with the CD-R/CD-RW discs before using.

## Additional Information

### Understanding built-in CD player error messages

When problems occur during CD play an error message may appear on the display. If an error message appears on the display refer to the table below to see what the problem is and the suggested method of correcting the problem. If the error cannot be corrected, contact your dealer or your nearest Pioneer Service Center.

Message	Cause	Action
<b>ERROR-11, 12, 17, 30</b>	Dirty disc	Clean disc.
<b>ERROR-11, 12, 17, 30</b>	Scratched disc	Replace disc.
<b>ERROR-22, 23</b>	The CD format cannot be played back.	Replace disc.
<b>ERROR-10, 11, 12, 17, 30, A0</b>	Electrical or mechanical	Turn the ignition ON and OFF, or switch to a different source, then back to the CD player.
<b>ERROR-44</b>	All tracks are skip tracks	Replace disc.





## MP3 files

- MP3 is short for MPEG Audio Layer 3 and refers to an audio compression technology standard.
- This product allows playback of MP3 files on CD-ROM, CD-R and CD-RW discs. Disc recordings compatible with level 1 and level 2 of ISO9660 and with the Romeo and Joliet file system can be played back.
- It is possible to play back multi-session compatible recorded discs.
- Files are compatible with the ID3 Tag Ver. 1.0 and Ver. 1.1 formats for display of album (disc title), track (track title) and artist (track artist).
- Only when MP3 files of 32, 44.1 and 48 kHz frequencies are played back, the emphasis function is valid. (16, 22.05, 24, 32, 44.1, 48 kHz sampling frequencies can be played back.)
- MP3 files are not compatible with packet write data transfer.
- There is no m3u playlist compatibility.
- There is no compatibility with the MP3i (MP3 interactive) or mp3 PRO format.
- The max. number of characters which can be displayed for a file name, including the extension (.mp3), is 32 characters from the first character.
- The max. number of characters which can be displayed for a folder name is 32 characters.
- In case of files recorded according to the Romeo or the Joliet file system, only the first 32 characters can be displayed.
- In case of discs with MP3 files mixed with CD-EXTRA, MIXED-MODE CD, and other audio data (CD DA), only the CD DA part can be played.
- When CD-R/CD-RW discs are used, playback is possible only for discs which have been finalized.

- The folder selection sequence for playback and other operations becomes the writing sequence used by the writing software. For this reason, the expected sequence at the time of playback may not coincide with the actual playback sequence. However, there also is some writing software which permits setting of the playback order.
- The sound quality of MP3 files generally becomes better with increasing bit rate. This unit can play recordings with bit rates from 16 kbps to 320 kbps, but in order to be able to enjoy a certain sound quality, it is recommended to use only discs recorded with a bit rate of at least 128 kbps.

### Precaution:

- When naming an MP3 file, add the corresponding filename extension (.mp3).
- This product plays back files with the filename extension (.mp3) as an MP3 file. To prevent noise and malfunctions, do not use this extension for files other than MP3 files.

## Additional Information

### About folders and MP3 files

- An outline of a CD-ROM with MP3 files on it is shown below. Subfolders are shown as folders in the folder currently selected.

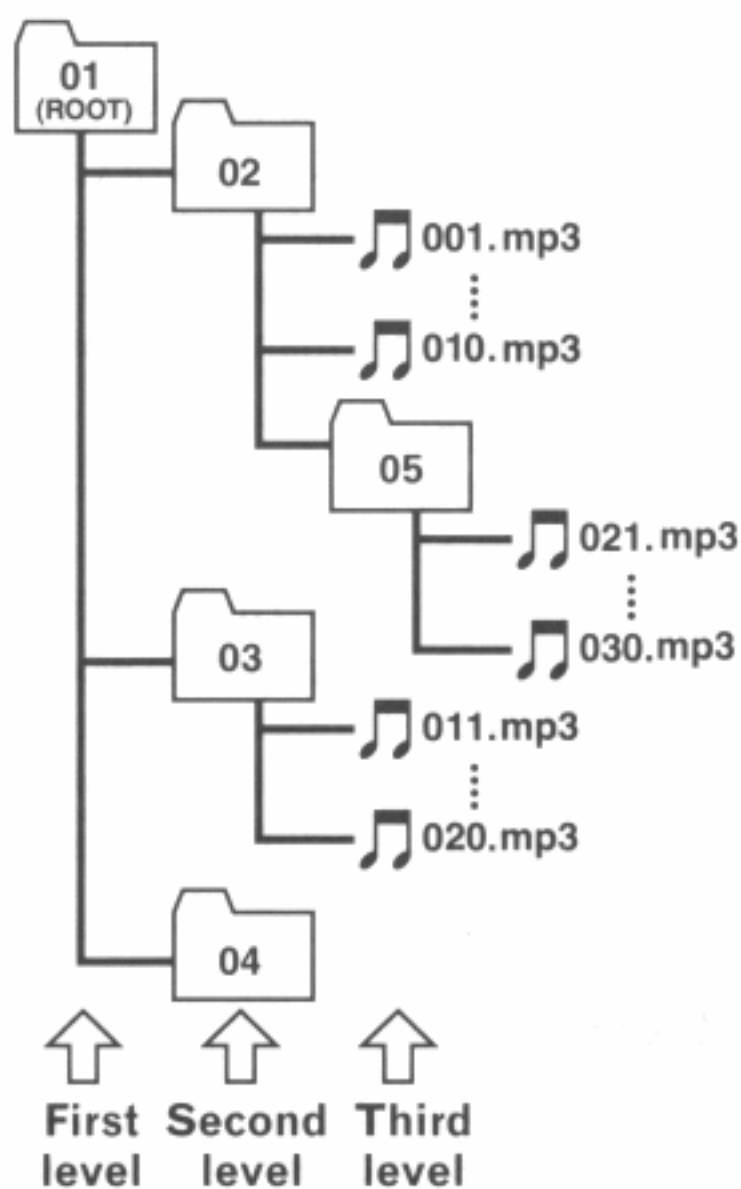

### Notes

- The equipment assigns folder numbers. The user can not assign folder numbers.
- If a disc contains both MP3 files and music data, only the music data will be played back. (The elapsed playback time for MP3 files is displayed, but there is no music output.)
- It is not possible to check folders that do not include MP3 files. (These folders will be skipped without displaying the folder number.)
- MP3 files in up to 8 tiers of folders can be played back. However, there is a delay in the start of playback on discs with numerous tiers. For this reason we recommend creating discs with no more than 2 tiers.
- It is possible to play back up to 253 items from folder on one disc. ▣

## Terms

### Bit rate

This expresses data volume per second, or bps units (bits per second). The higher the rate, the more information is available to reproduce the sound. Using the same encoding method (such as MP3), the higher the rate, the better the sound.

### ID3 Tag

This is a method of embedding track-related information in a MP3 file. This embedded information can include the track title, the artist's name, the album title, the music genre, the year of production, comments and other data. The contents can be freely edited using software with ID3 Tag editing functions. Although the tags are restricted to the number of characters, the information can be viewed when the track is played back.

### ISO9660 format

This is the international standard for the format logic of CD-ROM folders and files. For the ISO9660 format, there are regulations for the following two levels.

#### Level 1:

The file name is in 8.3 format (the name consists of up to 8 characters, half-byte English capital letters and half-byte numerals and the "\_" sign, with a file-extension of three characters.)

#### Level 2:

The file name can have up to 31 characters (including the separation mark "." and a file extension). Each folder contains less than 8 hierarchies.

### Extended formats

Joliet:

File names can have up to 64 characters.

Romeo:

File names can have up to 128 characters.

### m3u

Playlists created using the "WINAMP" software have a playlist file extension (.m3u).

### Multi-session

Multi-session is a recording method that allows additional data to be recorded later. When recording data on a CD-ROM, CD-R or CD-RW, etc., all data from beginning to end is treated as a single unit or session. Multi-session is a method of recording more than 2 sessions in one disc.

### MP3

MP3 is short for MPEG Audio Layer3. It is an audio compression standard set by a working group (MPEG) of the ISO (International Standards Organization). MP3 is able to compress audio data to about 1/10th the level of a conventional disc.

### Packet write

This is a general term for a method of writing on CD-R, etc. at the time required for a file, just as is done with files on floppy or hard discs.

### VBR

VBR is short for Variable Bit Rate. Generally speaking CBR (Constant Bit Rate) is more widely used. But to flexibly adjust the bit rate according to the needs of audio compression, it is possible to achieve compression prioritizes sound quality.

## Additional Information

### Specifications

#### General

Power source .....	14.4 V DC (10.8 – 15.1 V allowable)
Grounding system .....	Negative type
Max. current consumption .....	10.0 A
Dimensions (W × H × D):	
(DIN) Chassis .....	178 × 50 × 157 mm [7 × 2 × 6-1/8 in]
Nose .....	188 × 58 × 19 mm [7-3/8 × 2-1/4 × 3/4 in]
(D) Chassis .....	178 × 50 × 162 mm [7 × 2 × 6-3/8 in]
Nose .....	170 × 46 × 14 mm [6-3/4 × 1-3/4 × 1/2 in]
Weight .....	1.6 kg

#### Audio

Continuous power output is 22 W per channel min. into 4 ohms, both channels driven 50 to 15,000 Hz with no more than 5% THD.

Maximum power output .....	50 W × 4 for subwoofer (70 W × 1 ch/2 Ω)
Load impedance .....	4 Ω (4 – 8 Ω [2 Ω for 1 ch] allowable)
Preout max output level/output impedance .....	4 V/1 kΩ
Equalizer (3-Band Parametric Equalizer):	
(Low)	
Frequency .....	40/80/100/160 Hz
Q Factor .....	0.35/0.59/0.95/1.15 (+6 dB when boosted)
Gain .....	±12 dB
(Mid)	
Frequency .....	200/500/1 k/2 k Hz
Q Factor .....	0.35/0.59/0.95/1.15 (+6 dB when boosted)
Gain .....	±12 dB
(High)	
Frequency .....	3.15 k/8 k/10 k/12.5 k Hz
Q Factor .....	0.35/0.59/0.95/1.15 (+6 dB when boosted)
Gain .....	±12 dB
Loudness contour:	
(Low) .....	+3.5 dB (100 Hz) +3 dB (10 kHz)
(Mid) .....	+10 dB (100 Hz) +6.5 dB (10 kHz)
(High) .....	+11 dB (100 Hz) +11 dB (10 kHz) (Volume: -30 dB)

Tone controls:

(Bass)	
Frequency .....	40/63/100/160 Hz
Gain .....	±12 dB
(Treble)	
Frequency .....	2.5 k/4 k/6.3 k/10 k Hz
Gain .....	±12 dB

HPF:

Frequency .....	50/80/125 Hz
Slope .....	-12 dB/oct

Subwoofer:

Frequency .....	50/80/125 Hz
Slope .....	-18 dB/oct
Gain .....	±12 dB
Phase .....	Normal/Reverse

#### CD player

System .....	Compact disc audio system
Usable discs .....	Compact disc
Signal format:	
Sampling frequency ...	44.1 kHz
Number of quantization bits .....	16; linear
Frequency characteristics .....	5 – 20,000 Hz (±1 dB)
Signal-to-noise ratio .....	94 dB (1 kHz) (IHF-A network)
Dynamic range .....	92 dB (1 kHz)
Number of channels .....	2 (stereo)
MP3 decoding format .....	MPEG-1&2 Audio Layer-3

#### FM tuner

Frequency range .....	87.9 – 107.9 MHz
Usable sensitivity .....	9 dBf (0.8 μV/75 Ω, mono, S/N:30 dB)
50 dB quieting sensitivity ...	15 dBf (1.5 μV/75 Ω, mono)
Signal-to-noise ratio .....	70 dB (IHF-A network)
Distortion .....	0.3% (at 65 dBf, 1 kHz, stereo)
Frequency response .....	30 – 15,000 Hz (± 3 dB)
Stereo separation .....	40 dB (at 65 dBf, 1 kHz)
Selectivity .....	70 dB
Three signal intermodulation (Desire signal level) ...	30 dBf (two undesire signal level: 100 dBf)

#### AM tuner

Frequency range .....	530 – 1,710 kHz (10 kHz)
Usable sensitivity .....	18 μV (S/N: 20 dB)
Selectivity .....	50 dB (± 10 kHz)



#### Note

- Specifications and the design are subject to possible modifications without notice due to improvements. ■